

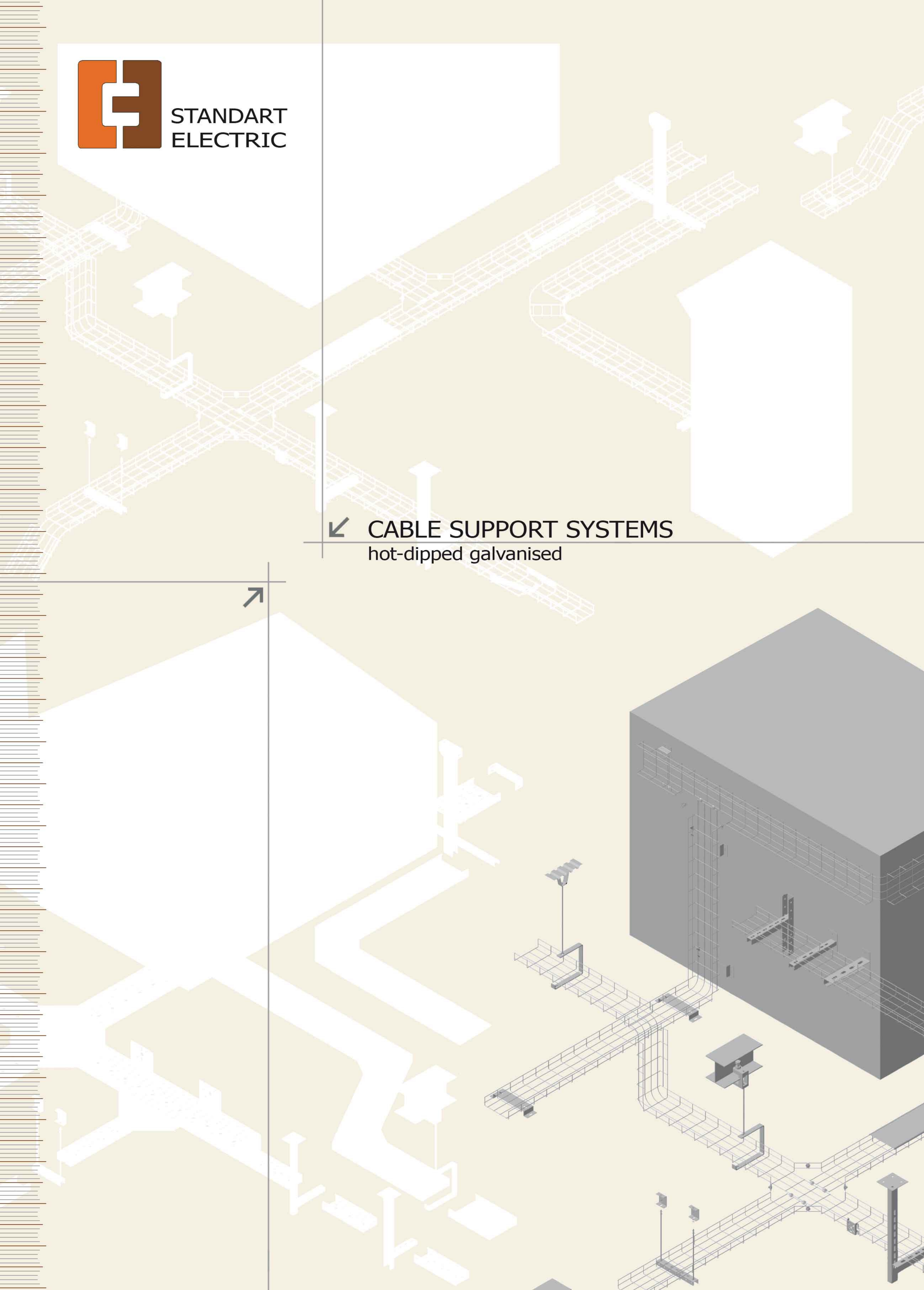

STANDART
ELECTRIC

↙ **CABLE SUPPORT SYSTEMS**
hot-dipped galvanised

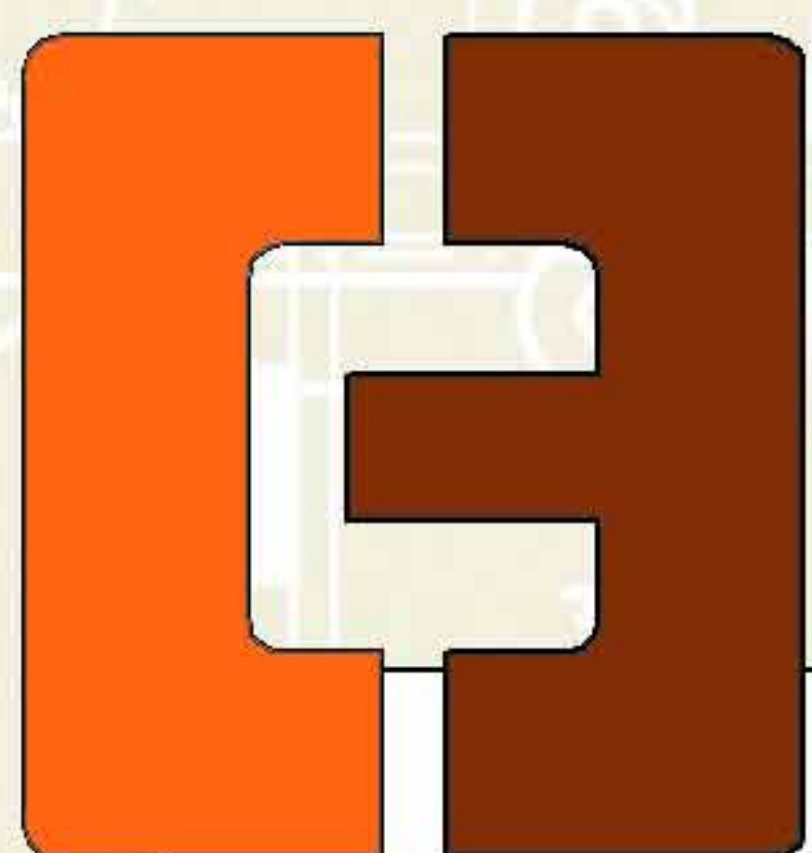



STANDART
ELECTRIC

Contents:

1) Perforated Cable Tray Systems.....	1-4
2) Ladder Type Cable Trays Systems.....	5-14
3) Vertical Ladder Type Cable Trays.....	15-16

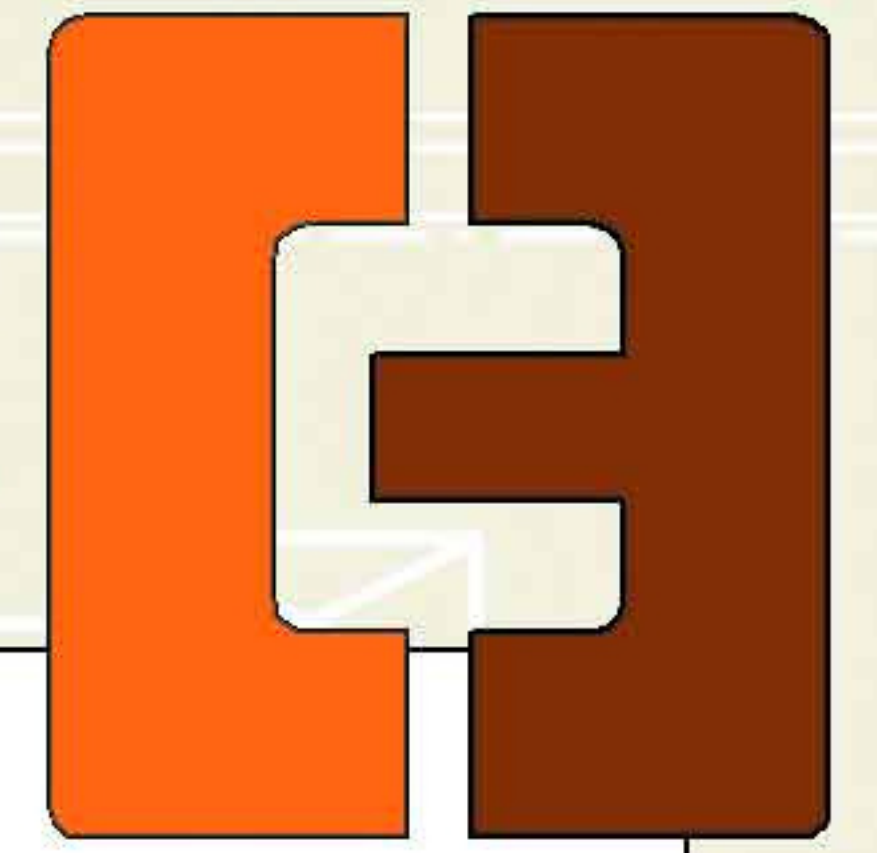

LNS cable tray without perforation

Type	Height H, mm	Width B, mm	Length L, mm	Thickness S, mm	Weight, kg/r.m. mm	Part number
LNS 50x50x0,7	50	50	3000	0,7	0,868	400010
LNS 50x75x0,7	50	75	3000	0,7	1,010	400020
LNS 50x100x0,8	50	100	3000	0,8	1,160	400030
LNS 50x150x0,8	50	150	3000	0,8	2,070	400040
LNS 50x225x0,9	50	225	3000	0,9	2,395	400050
LNS 50x225x1,2	50	225	3000	1,2	3,193	400060
LNS 50x300x1,2	50	300	3000	1,2	3,910	400070
LNS 50x400x1,0	50	400	3000	1,0	3,970	400080

Coating types:

- 1) Electro galvanized (2,5-10 mm)
- 2) Zink coating acc.to Sendzimir method (19-20 mm)
- 3) Hot dipped galvanized (50-100 mm)

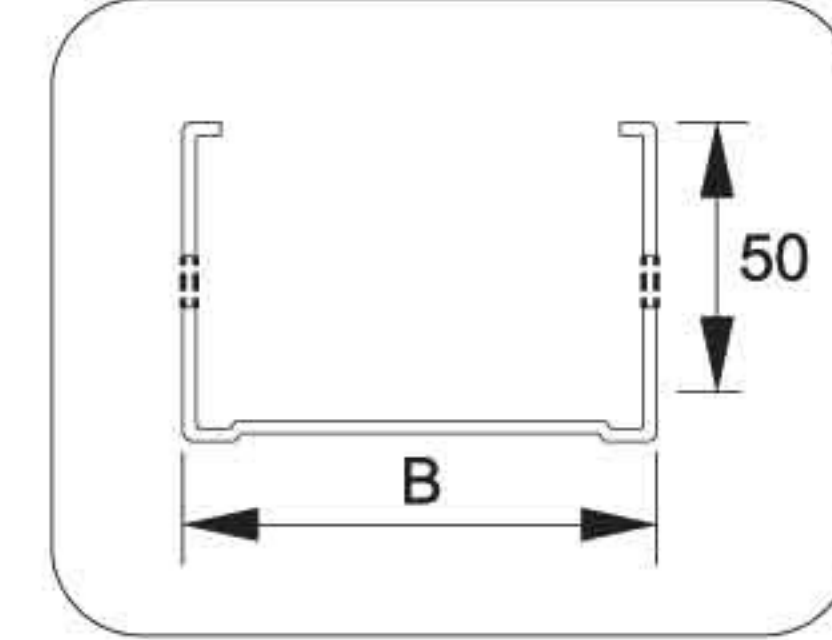

LPS cable tray perforated along the bottom (one row)

Type	Height H, mm	Width B, mm	Length L, mm	Thickness S, mm	Weight, kg/r.m. mm	Part number
LPS 50x50x0,7	50	50	3000	0,7	0,868	400090
LPS 50x75x0,7	50	75	3000	0,7	1,010	400100
LPS 50x100x0,7	50	100	3000	0,8	1,160	400110

Coating types:

- 1) Electro galvanized (2,5-10 mm)
- 2) Zink coating acc.to Sendzimir method (19-20 mm)
- 3) Hot dipped galvanized (50-100 mm)

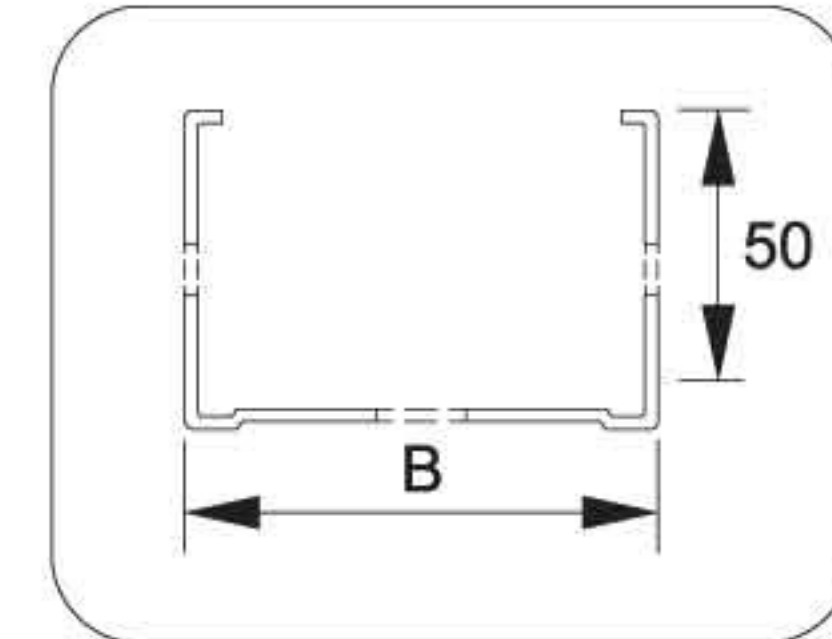

LPS cable tray perforated

Type	Height H, mm	Width B, mm	Length L, mm	Thickness S, mm	Weight, kg/r.m. mm	Part number
LPS 50x100x0,8	50	100	3000	0,8	1,346	400120
LPS 50x150x0,8	50	150	3000	0,8	1,650	400130
LPS 50x225x0,9	50	225	3000	0,9	1,933	400140
LPS 50x225x1,2	50	225	3000	1,2	2,578	400150
LPS 50x300x1,2	50	300	3000	1,2	3,304	400160
LPS 50x400x1,0	50	400	3000	1,0	3,506	400170

Coating types:

- 1) Electro galvanized (2,5-10 mm)
- 2) Zink coating acc.to Sendzimir method (19-20 mm)
- 3) Hot dipped galvanized (50-100 mm)

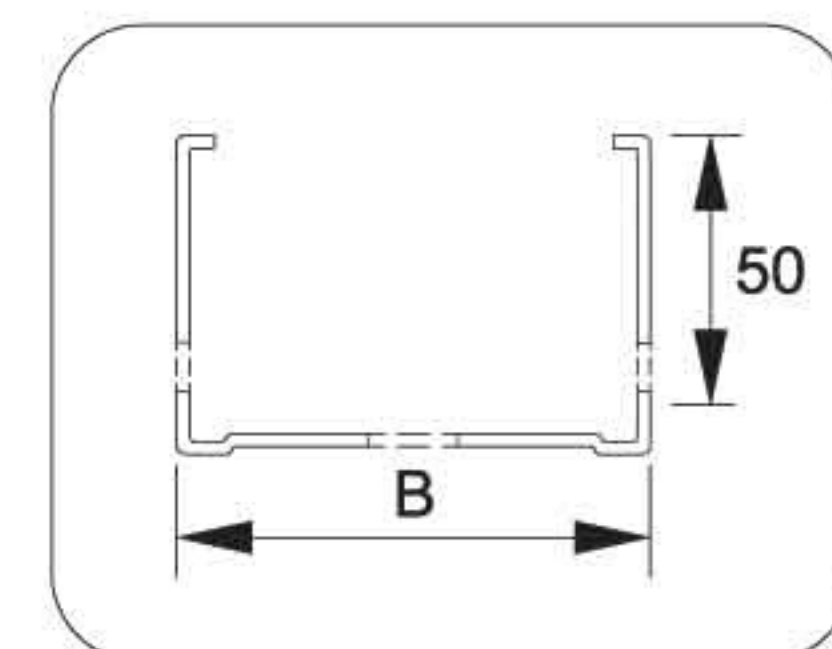

HA 90° horizontal bend 90°

Type	Height H, mm	Width B, mm	Length L, mm	Thickness S, mm	Weight, kg/quantity	Part number
HA 50x100x0,7	50	273,4	273,4	0,7	0,398	400180
HA 50x150x0,7	50	323,4	323,4	0,7	0,626	400190
HA 50x225x1,0	50	397,6	397,6	1,0	1,154	400200
HA 50x300x1,0	50	472,6	472,6	1,0	1,595	400210
HA 50x400x1,0	50	522,0	522,0	1,0	1,850	400220

Coating types:

- 1) Electro galvanized (2,5-10 mm)
- 2) Zink coating acc.to Sendzimir method (19-20 mm)
- 3) Hot dipped galvanized (50-100 mm)

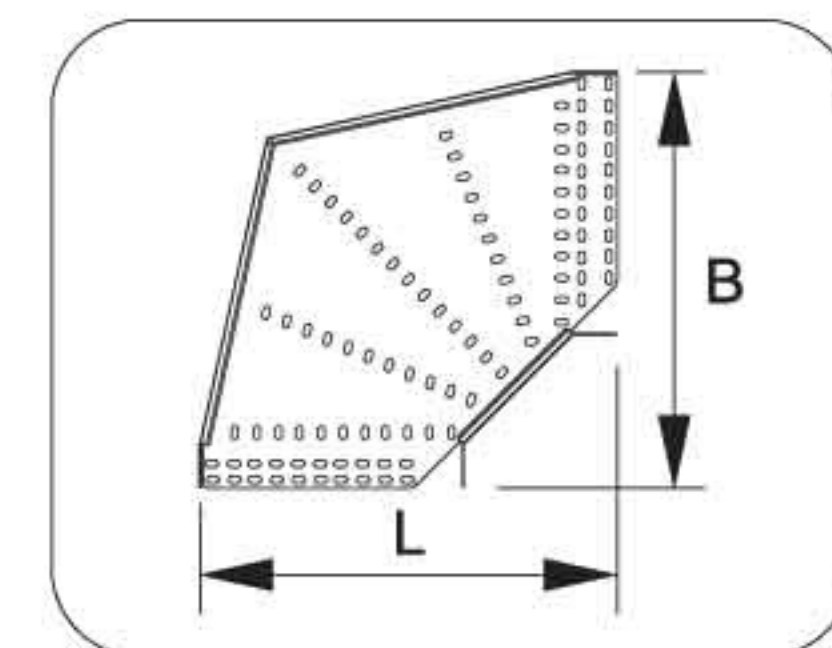

CS cross-over

Type	Height H, mm	Width B, mm	Length L, mm	Thickness S, mm	Weight, kg/quantity	Part number
CS 50x100x0,7	50	50,7	448,4	448,4	0,632	400230
CS 50x150x0,7	50	50,7	498,4	498,4	0,867	400240
CS 50x225x1,0	50	51,0	572,6	572,6	1,281	400250
CS 50x300x1,0	50	51,0	647,6	647,6	2,940	400260
CS 50x400x1,0	50	51,0	747,0	747,0	3,000	400270

Coating types:

- 1) Electro galvanized (2,5-10 mm)
- 2) Zink coating acc.to Sendzimir method (19-20 mm)
- 3) Hot dipped galvanized (50-100 mm)

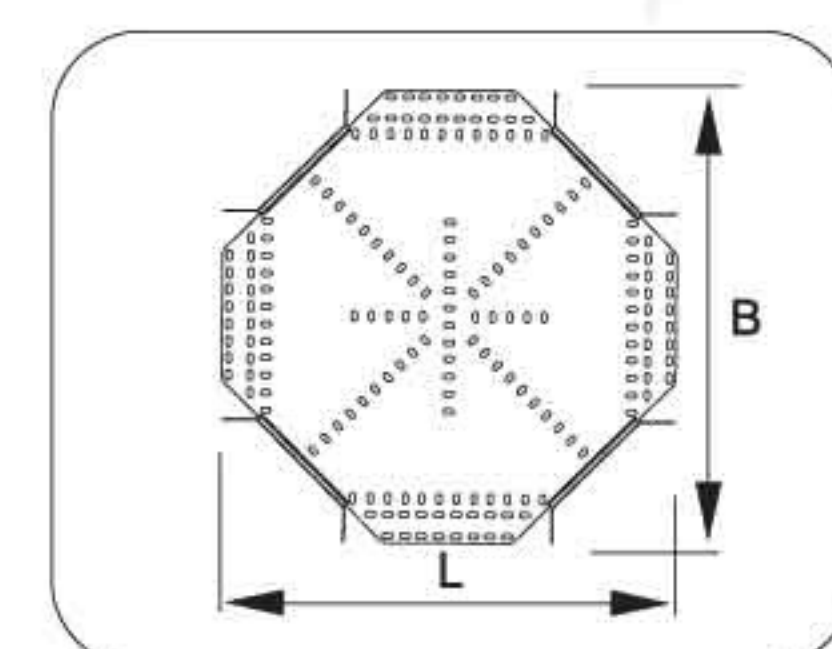



**STANDART
ELECTRIC**

TCS T-piece

Type	Height H, mm	Width B, mm	Length L, mm	Thickness S, mm	Weight, kg/quantity	Part number
TCS 50x100x0,7	50	50,7	273,4	450,0	0,615	400280
TCS 50x150x0,7	50	50,7	323,4	500,0	0,932	400290
TCS 50x225x1,0	50	51,0	397,6	575,0	1,673	400300
TCS 50x300x1,0	50	51,0	472,6	650,0	2,256	400310
TCS 50x400x1,0	50	51,0	522,0	750,0	2,680	400320

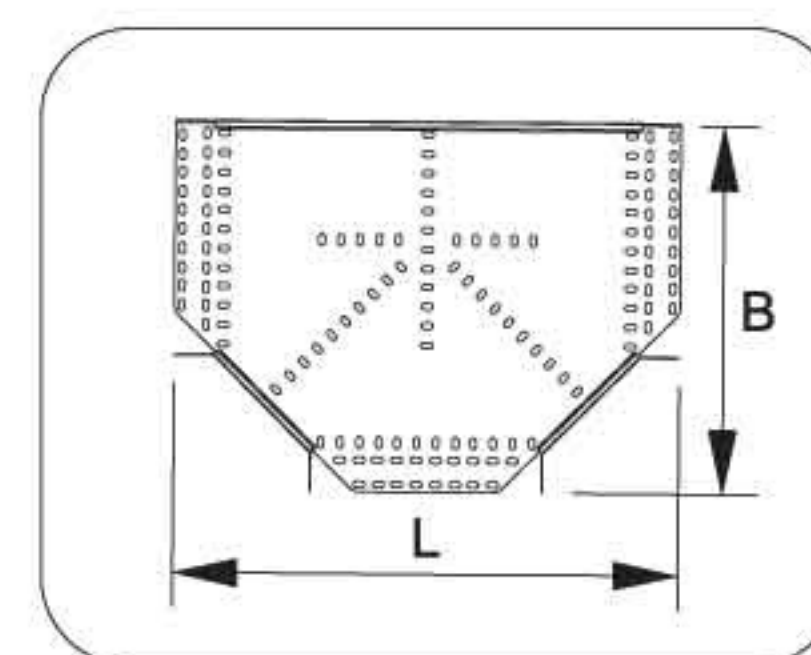

Coating types:

- 1) Electro galvanized (2,5-10 mm)
- 2) Zink coating acc.to Sendzimir method (19-20 mm)
- 3) Hot dipped galvanized (50-100 mm)

LVI 90° vertical inside bend

Type	Height H, mm	Width B, mm	Length L, mm	Thickness S, mm	Weight, kg/quantity	Part number
LVI 50x100x0,7	50,7	98,4	450,0	0,7	0,567	400330
LVI 50x150x0,7	50,7	148,4	450,0	0,7	0,712	400340
LVI 50x225x1,0	51,0	222,6	450,0	1,0	1,185	400350
LVI 50x300x1,0	51,0	297,6	450,0	1,0	1,630	400360
LVI 50x400x1,0	51,0	397,6	450,0	1,0	0,800	400370

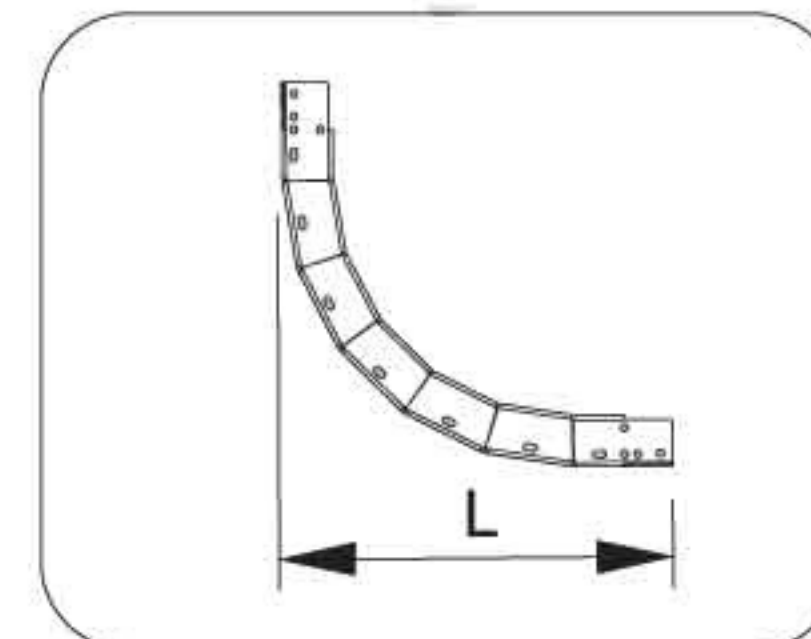

Coating types:

- 1) Electro galvanized (2,5-10 mm)
- 2) Zink coating acc.to Sendzimir method (19-20 mm)
- 3) Hot dipped galvanized (50-100 mm)

LVE 90° vertical outside bend

Type	Height H, mm	Width B, mm	Length L, mm	Thickness S, mm	Weight, kg/quantity	Part number
LVE 50x100x0,7	50,7	98,4	450,0	0,7	0,567	400380
LVE 50x150x0,7	50,7	148,4	450,0	0,7	0,712	400390
LVE 50x225x1,0	51,0	222,6	450,0	1,0	1,185	400400
LVE 50x300x1,0	51,0	297,6	450,0	1,0	1,630	400410
LVE 50x400x1,0	51,0	397,6	450,0	1,0	0,800	400420

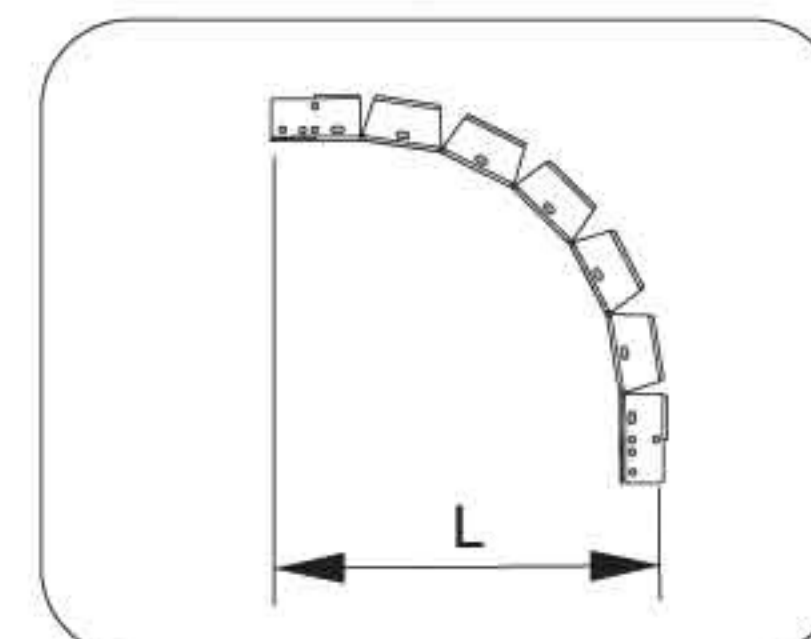

Coating types:

- 1) Electro galvanized (2,5-10 mm)
- 2) Zink coating acc.to Sendzimir method (19-20 mm)
- 3) Hot dipped galvanized (50-100 mm)

KLF cable tray cover

Type	Height H, mm	Width B, mm	Length L, mm	Thickness S, mm	Weight, kg/r.m. mm	Part number
KLF 12x50x0,7	12	50	3000	0,7	0,380	400430
KLF 12x75x0,7	12	75	3000	0,7	0,520	400440
KLF 12x100x0,7	12	100	3000	0,8	0,740	400450
KLF 12x150x0,7	12	150	3000	0,8	1,060	400460
KLF 12x225x0,9	12	225	3000	0,9	1,535	400470
KLF 12x225x1,2	12	225	3000	1,2	1,724	400480
KLF 12x300x0,7	12	300	3000	1,2	2,996	400490
KLF 12x400x0,7	12	400	3000	0,8	2,570	400500

Coating types:

- 1) Electro galvanized (2,5-10 mm)
- 2) Zink coating acc.to Sendzimir method (19-20 mm)
- 3) Hot dipped galvanized (50-100 mm)

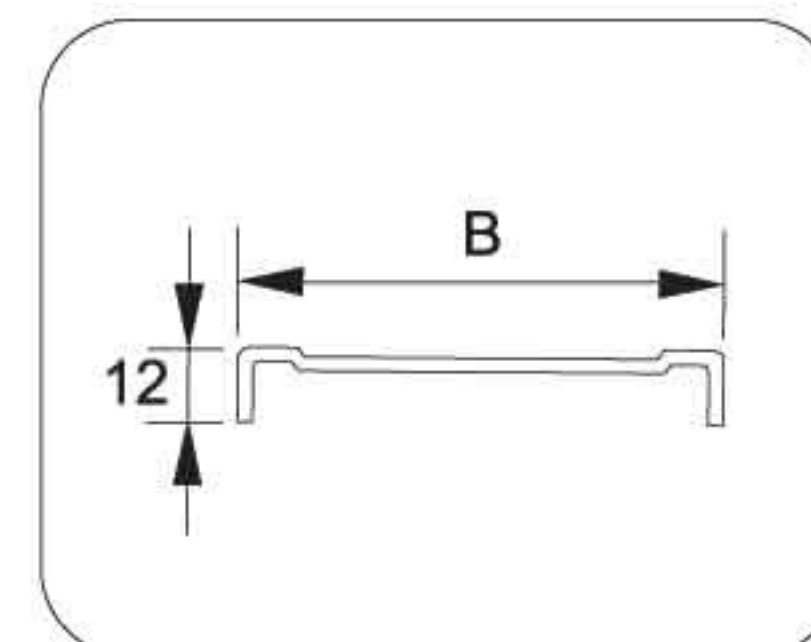

KHA 90° cover for horizontal bend 90°

Type	Height H, mm	Width B, mm	Length L, mm	Thickness S, mm	Weight, kg/quantity	Part number
KHA 12x100x0,9	12	230	230	0,9	0,254	400510
KHA 12x150x0,9	12	280	280	0,9	0,391	400520
KHA 12x225x0,9	12	355	355	0,9	0,645	400530
KHA 12x300x1,5	12	430	430	1,5	1,597	400540
KHA 12x400x0,8	12	530	530	0,8	1,210	400550

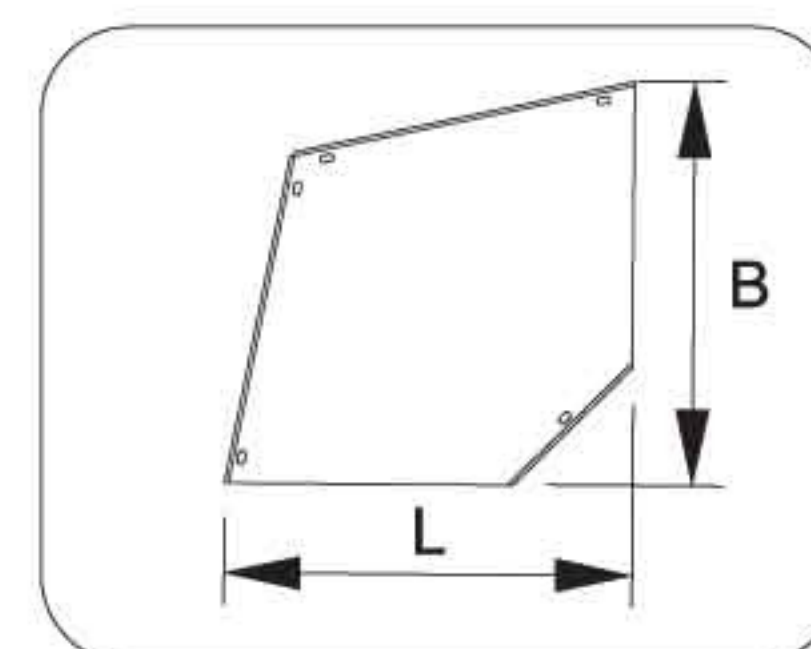

Coating types:

- 1) Electro galvanized (2,5-10 mm)
- 2) Zink coating acc.to Sendzimir method (19-20 mm)
- 3) Hot dipped galvanized (50-100 mm)

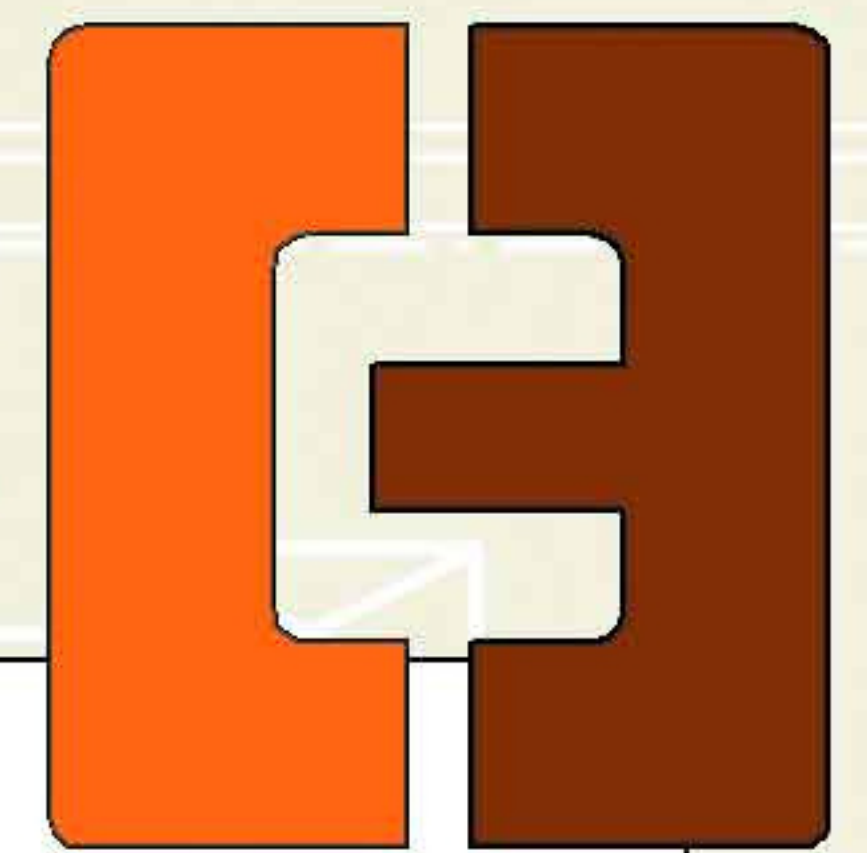

KCS cover for cross-over

Type	Height H, mm	Width B, mm	Length L, mm	Thickness S, mm	Weight, kg/quantity	Part number
KCS 12x100x0,9	12	347,6	347,6	0,9	0,732	400560
KCS 12x150x0,9	12	397,6	397,6	0,9	0,949	400570
KCS 12x225x0,9	12	472,6	472,6	0,9	1,881	400580
KCS 12x300x1,5	12	547,6	547,6	1,5	2,486	400590
KCS 12x400x0,8	12	530,0	530,0	0,8	2,180	400600

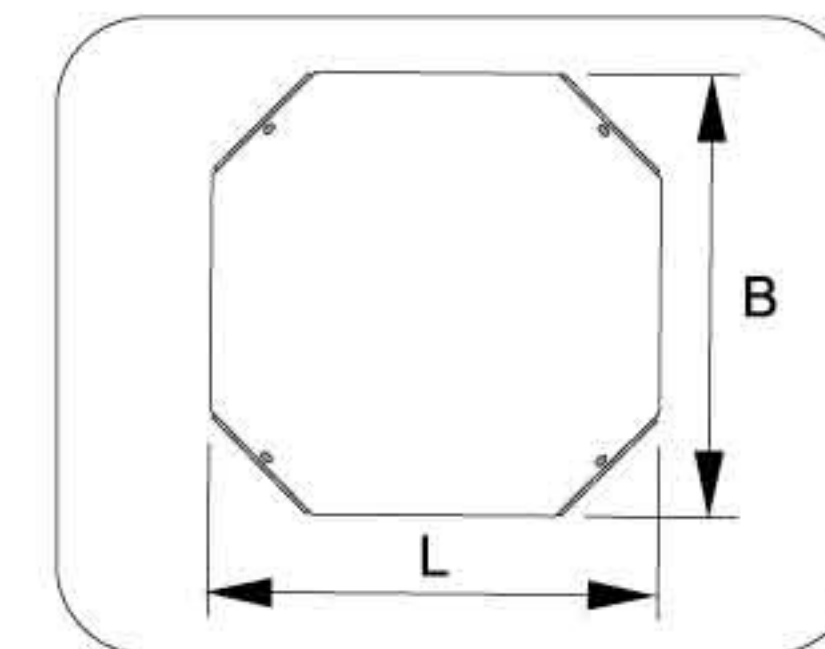

Coating types:

- 1) Electro galvanized (2,5-10 mm)
- 2) Zink coating acc.to Sendzimir method (19-20 mm)
- 3) Hot dipped galvanized (50-100 mm)

KTCS cover for T-piece

Type	Height H, mm	Width B, mm	Length L, mm	Thickness S, mm	Weight, kg/quantity	Part number
KTCS 12x100x0,9	12	228,6	347,6	0,9	0,456	400610
KTCS 12x150x0,9	12	278,8	397,6	0,9	0,657	400620
KTCS 12x225x0,9	12	353,8	472,6	0,9	1,018	400630
KTCS 12x300x1,5	12	428,8	547,6	1,5	2,417	400640
KTCS 12x400x0,8	12	528,8	647,6	0,8	1,840	400650

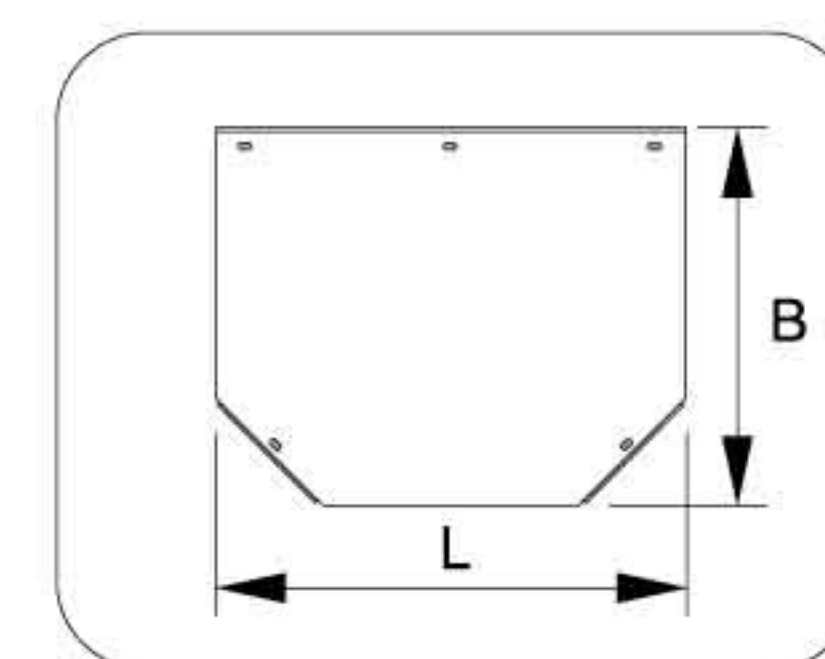

Coating types:

- 1) Electro galvanized (2,5-10 mm)
- 2) Zink coating acc.to Sendzimir method (19-20 mm)
- 3) Hot dipped galvanized (50-100 mm)

KLVI 90° cover for vertical inside bend

Type	Height H, mm	Width B, mm	Length L, mm	Thickness S, mm	Weight, kg/quantity	Part number
KLVI 12x100x0,9	12	110	392,7	0,9	0,251	400660
KLVI 12x150x0,9	12	160	392,7	0,9	0,313	400670
KLVI 12x225x0,9	12	235	392,7	0,9	0,436	400680
KLVI 12x300x0,9	12	310	392,7	0,9	0,622	400690
KLVI 12x400x0,9	12	410	647,6	0,8	0,480	400700

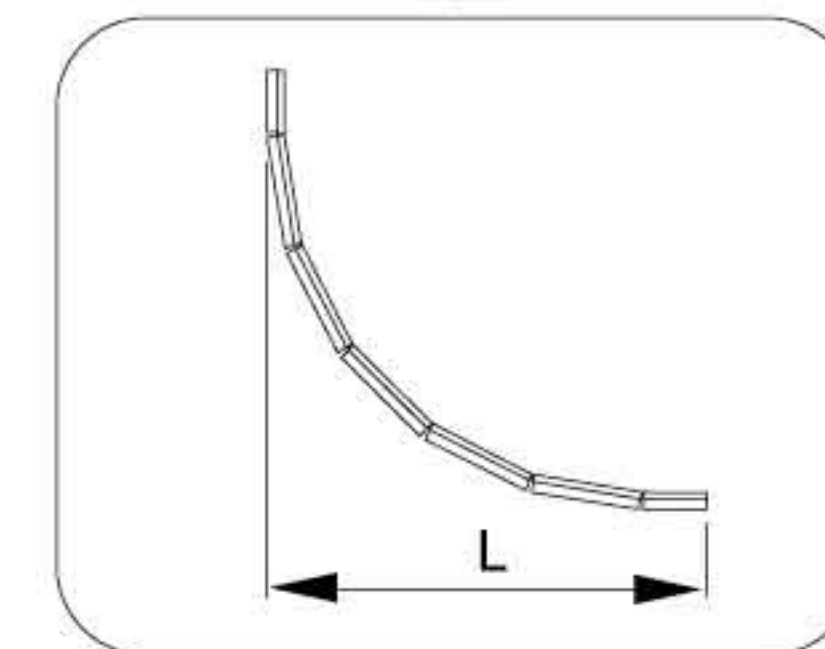

Coating types:

- 1) Electro galvanized (2,5-10 mm)
- 2) Zink coating acc.to Sendzimir method (19-20 mm)
- 3) Hot dipped galvanized (50-100 mm)

KLVE 90° cover for vertical outside bend

Type	Height H, mm	Width B, mm	Length L, mm	Thickness S, mm	Weight, kg/quantity	Part number
KLVE 12x100x0,9	12	110	392,7	0,9	0,251	400710
KLVE 12x150x0,9	12	160	392,7	0,9	0,313	400720
KLVE 12x225x0,9	12	235	392,7	0,9	0,436	400730
KLVE 12x300x0,9	12	310	392,7	0,9	0,622	400740
KLVE 12x400x0,9	12	410	647,6	0,8	0,480	400750

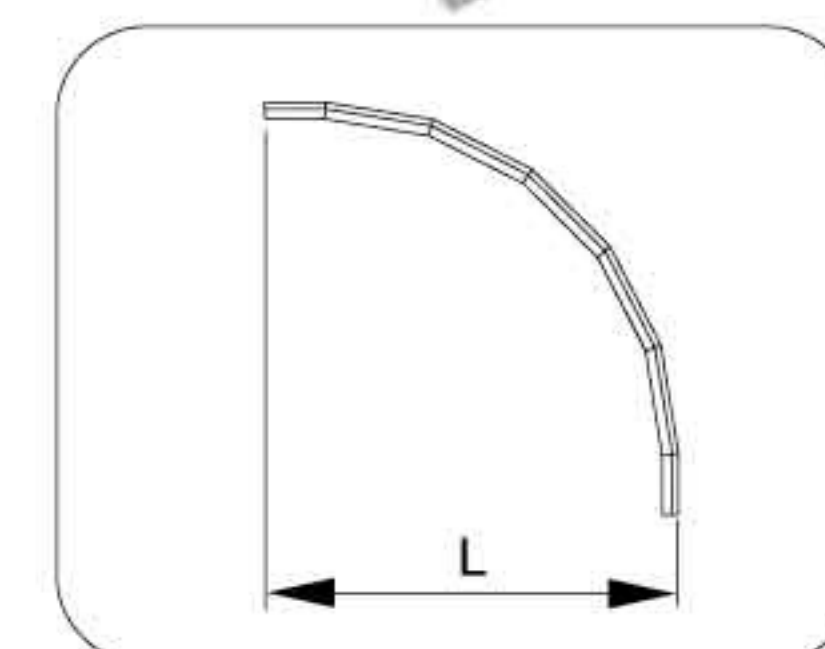

Coating types:

- 1) Electro galvanized (2,5-10 mm)
- 2) Zink coating acc.to Sendzimir method (19-20 mm)
- 3) Hot dipped galvanized (50-100 mm)

LCU connector for cable tray

Type	Height H, mm	Width B, mm	Length L, mm	Thickness S, mm	Weight, kg/quantity	Part number
LCU 35x21,5x1,2	35	21,5	200	1,2	0,140	400760
LCU 35x21,5x1,5	35	21,5	200	1,5	0,140	400770
	55	25,0	200	1,5	0,200	400780

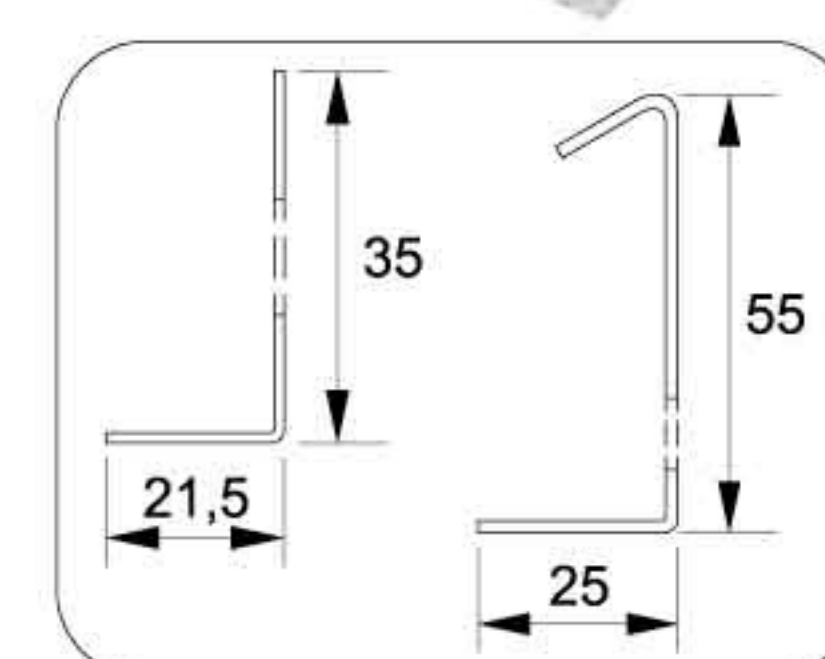

Coating types:

- 1) Electro galvanized (2,5-10 mm)
- 2) Zink coating acc.to Sendzimir method (19-20 mm)
- 3) Hot dipped galvanized (50-100 mm)



**STANDART
ELECTRIC**

LKHS hinged tray connector

Type	Height H, mm	Length L, mm	Thickness S, mm	Weight, kg/quantity	Part number
LKHS 132x45x1,5	45	132	1,2 KCS	0,065	400790

Coating types:

- 1) Electro galvanized (2,5-10 mm)
- 2) Zink coating acc.to Sendzimir method (19-20 mm)
- 3) Hot dipped galvanized (50-100 mm)

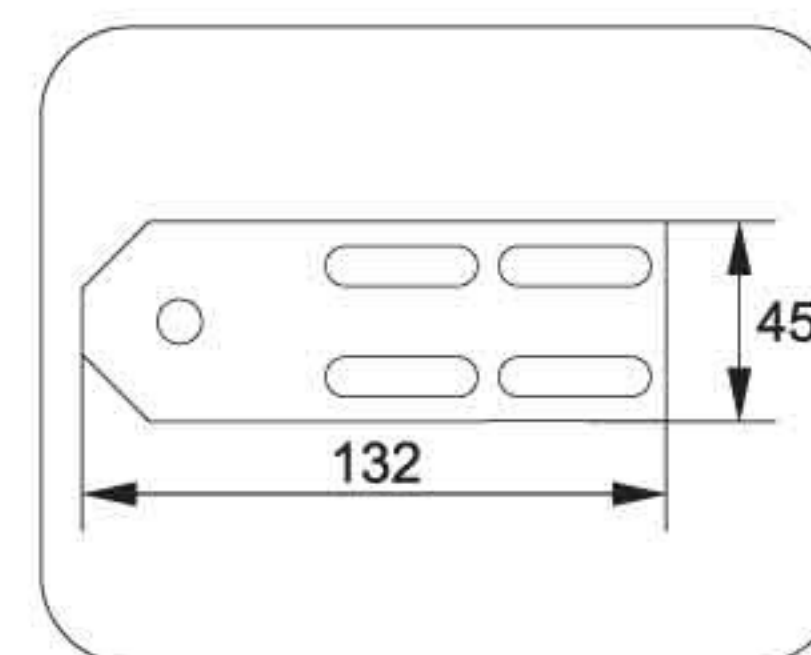

LLC tray bracket connector

Type	Height H, mm	Width B, mm	Length L, mm	Thickness S, mm	Weight, kg/quantity	Part number
LLC 70x50x2,0	70	50,0	325	2,0	0,334	400800

Coating types:

- 1) Electro galvanized (2,5-10 mm)
- 2) Zink coating acc.to Sendzimir method (19-20 mm)
- 3) Hot dipped galvanized (50-100 mm)

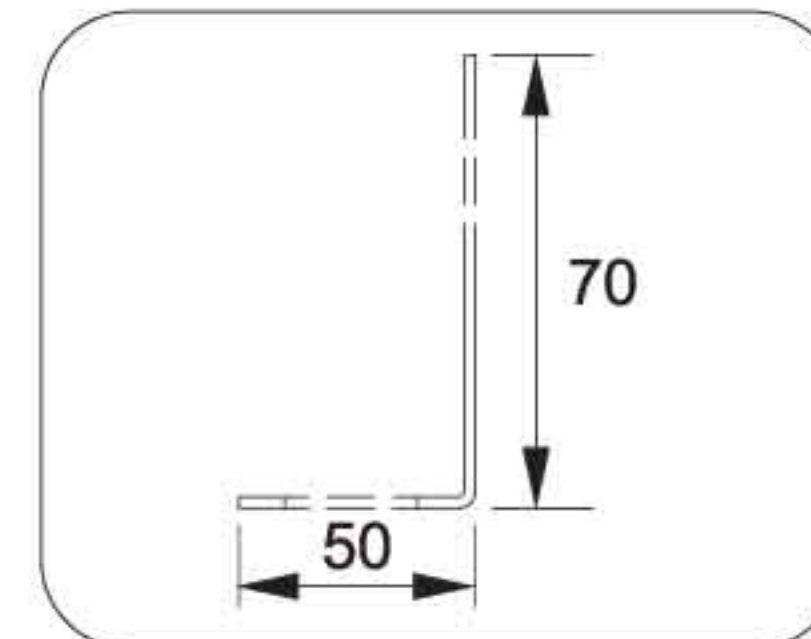

LEL division plate

Type	Height H, mm	Width B, mm	Length L, mm	Thickness S, mm	Weight, kg/quantity	Part number
LEL 48x25x1,2	48	25	3000	1,20	0,660	400810

Coating types:

- 1) Electro galvanized (2,5-10 mm)
- 2) Zink coating acc.to Sendzimir method (19-20 mm)
- 3) Hot dipped galvanized (50-100 mm)

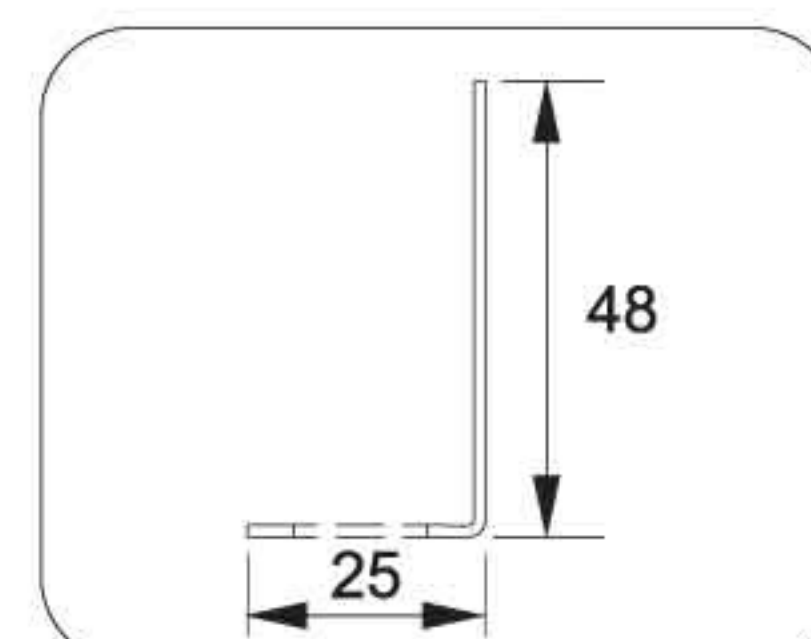

CPS folded mounting plate

Type	Height H, mm	Width B, mm	Length L, mm	Thickness S, mm	Weight, kg/quantity	Part number
CPS 4	154	25	160	4,00	0,920	400820
CPS 2	154	25	160	2,00		400830
CPS 1,5	154	25	160	1,50		400840

Coating types:

- 1) Electro galvanized (2,5-10 mm)
- 2) Zink coating acc.to Sendzimir method (19-20 mm)
- 3) Hot dipped galvanized (50-100 mm)

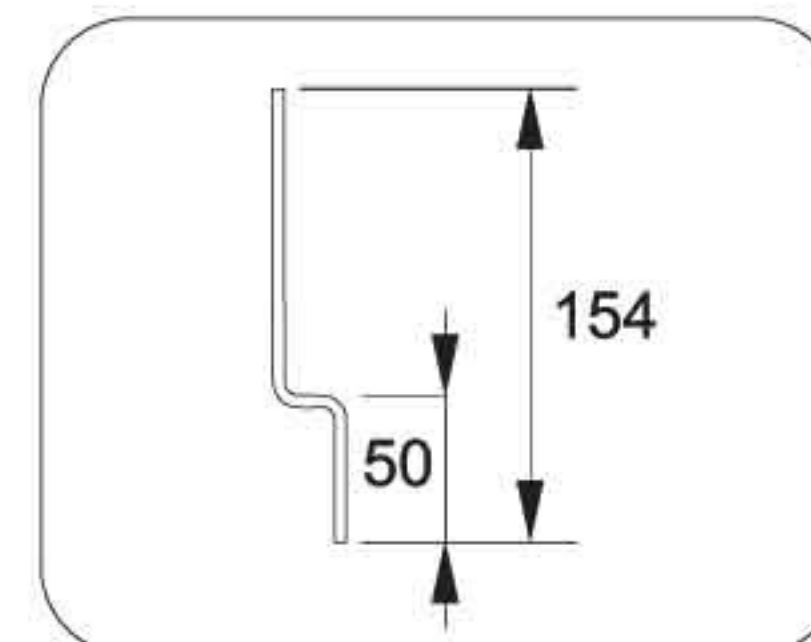

FKL fixing for tray cover

Type	Height H, mm	Width B, mm	Length L, mm	Thickness S, mm	Weight, kg/quantity	Part number
FKL 50	25	13	50	0,55	0,016	400850

Coating types:

- 1) Electro galvanized (2,5-10 mm)
- 2) Zink coating acc.to Sendzimir method (19-20 mm)
- 3) Hot dipped galvanized (50-100 mm)

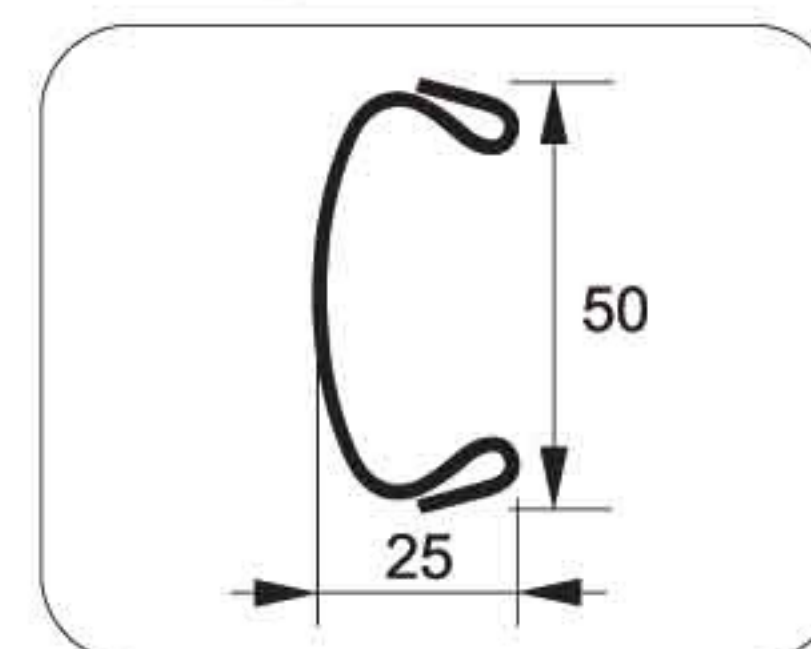

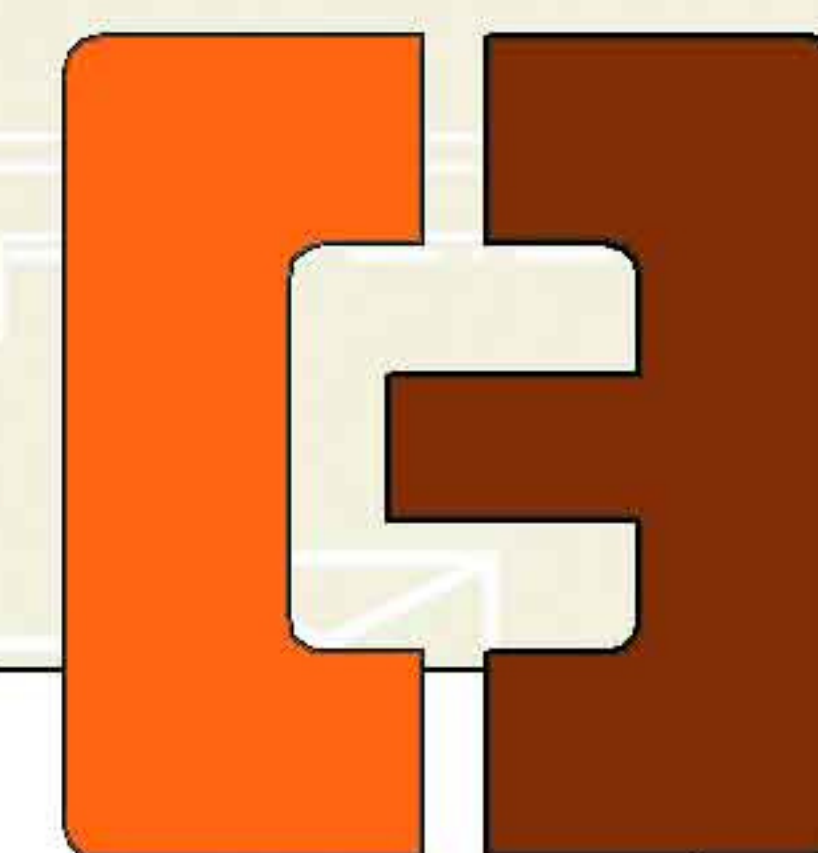

SL 50 ladder type cable tray/straight section

Type	Height H, mm	Width B, mm	Length L, mm	Thickness S, mm	Weight, kg/quantity	Part number
SL 50x200	50	200	3000	1,2	6,559	400860
SL 50x200	50	200	6000	1,2	13,118	400870
SL 50x300	50	300	3000	1,2	7,496	400890
SL 50x300	50	300	6000	1,2	14,992	400900
SL 50x400	50	400	3000	1,2	8,433	400910
SL 50x400	50	400	6000	1,2	16,866	400920
SL 50x500	50	500	3000	1,2	9,370	400930
SL 50x500	50	500	6000	1,2	18,740	400940
SL 50x600	50	600	3000	1,2	10,307	400950
SL 50x600	50	600	6000	1,2	20,614	400960
SL 50x200	50	200	3000	1,5	8,199	400970
SL 50x200	50	200	6000	1,5	16,398	400980
SL 50x300	50	300	3000	1,5	9,370	400990
SL 50x300	50	300	6000	1,5	18,740	410010
SL 50x400	50	400	3000	1,5	10,541	410020
SL 50x400	50	400	6000	1,5	21,082	410030
SL 50x500	50	500	3000	1,5	11,712	410040
SL 50x500	50	500	6000	1,5	23,424	410050
SL 50x600	50	600	3000	1,5	12,883	410060
SL 50x600	50	600	6000	1,5	25,766	410070
SL 50x200	50	200	3000	1,8	9,850	410080
SL 50x200	50	200	6000	1,8	19,708	410090
SL 50x300	50	300	3000	1,8	11,330	410100
SL 50x300	50	300	6000	1,8	22,660	410110
SL 50x400	50	400	3000	1,8	12,820	410120
SL 50x400	50	400	6000	1,8	25,640	410130
SL 50x500	50	500	3000	1,8	14,300	410140
SL 50x500	50	500	6000	1,8	28,600	410150
SL 50x600	50	600	3000	1,8	15,780	410160
SL 50x600	50	600	6000	1,8	31,568	410170

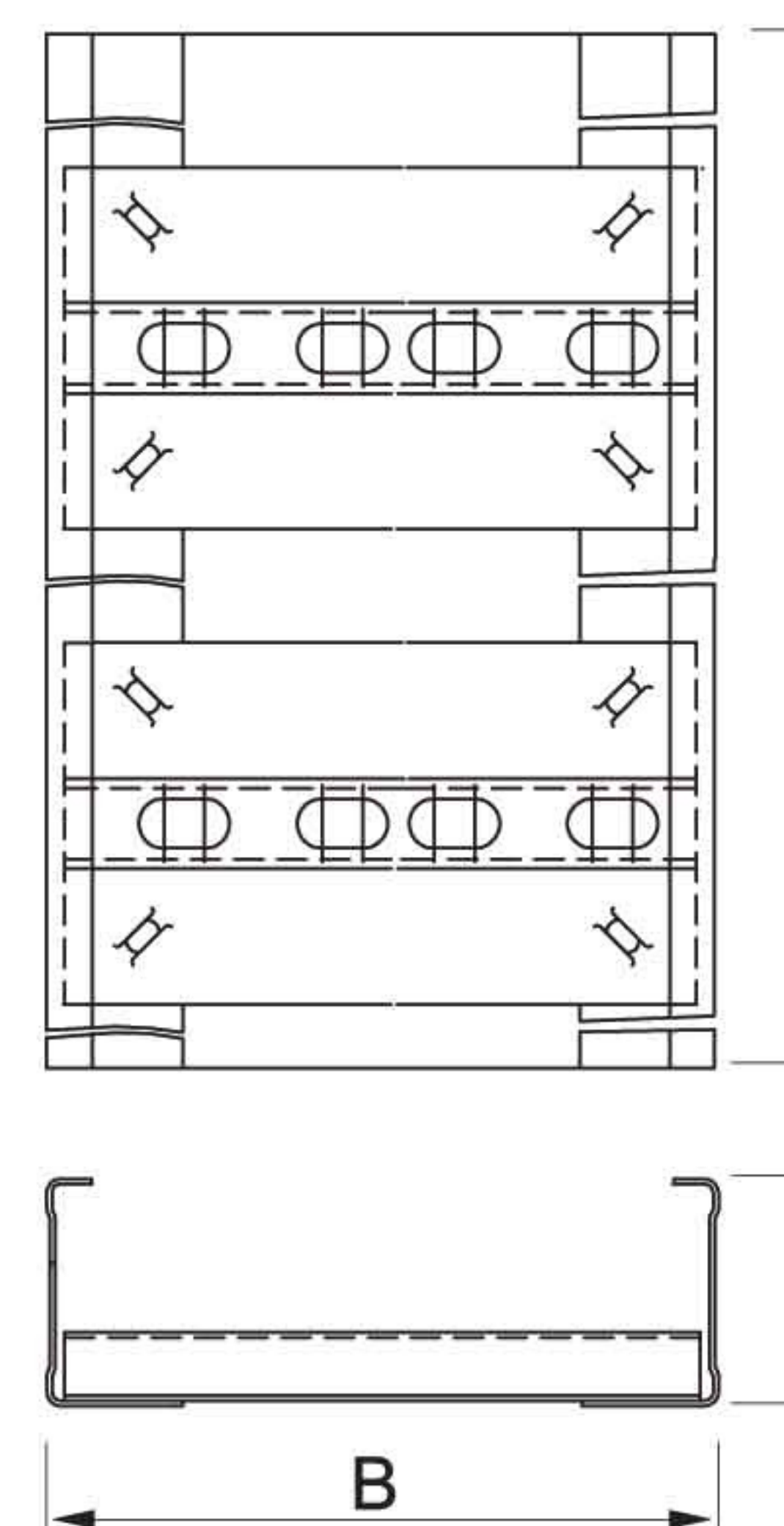

Coating types:

- 1) Electro galvanized (2,5-10 mm)
- 2) Zink coating acc.to Sendzimir method (19-20 mm)
- 3) Hot dipped galvanized (50-100 mm)

SL 75 ladder type cable tray/straight section

Type	Height H, mm	Width B, mm	Length L, mm	Thickness S, mm	Weight, kg/quantity	Part number
SL 75x200	75	200	3000	1,2	7,796	410180
SL 75x200	75	200	6000	1,2	15,592	410190
SL 75x300	75	300	3000	1,2	8,769	410200
SL 75x300	75	300	6000	1,2	17,538	410210
SL 75x400	75	400	3000	1,2	9,742	410220
SL 75x400	75	400	6000	1,2	19,484	410230
SL 75x500	75	500	3000	1,2	10,715	410240
SL 75x500	75	500	6000	1,2	21,430	410250
SL 75x600	75	600	3000	1,2	11,688	410260
SL 75x600	75	600	6000	1,2	23,376	410270
SL 75x200	75	200	3000	1,5	9,745	410280
SL 75x200	75	200	6000	1,5	19,490	410290
SL 75x300	75	300	3000	1,5	10,961	410300
SL 75x300	75	300	6000	1,5	21,922	410310
SL 75x400	75	400	3000	1,5	12,178	410320
SL 75x400	75	400	6000	1,5	24,356	410330
SL 75x500	75	500	3000	1,5	13,394	410340
SL 75x500	75	500	6000	1,5	26,788	410350
SL 75x600	75	600	3000	1,5	14,610	410360
SL 75x600	75	600	6000	1,5	29,220	410370
SL 75x200	75	200	3000	1,8	11,548	410380
SL 75x200	75	200	6000	1,8	23,096	410390
SL 75x300	75	300	3000	1,8	13,028	410400
SL 75x300	75	300	6000	1,8	26,056	410410
SL 75x400	75	400	3000	1,8	14,518	410420
SL 75x400	75	400	6000	1,8	29,036	410430
SL 75x500	75	500	3000	1,8	15,998	410440
SL 75x500	75	500	6000	1,8	31,996	410450
SL 75x600	75	600	3000	1,8	17,478	410460
SL 75x600	75	600	6000	1,8	34,956	410470

Coating types:

- 1) Electro galvanized (2,5-10 mm)
- 2) Zink coating acc.to Sendzimir method (19-20 mm)
- 3) Hot dipped galvanized (50-100 mm)



**STANDART
ELECTRIC**

SL 100 ladder type cable tray/straight section

Type	Height H, mm	Width B, mm	Length L, mm	Thickness S, mm	Weight, kg/quantity	Part number
SL 100x200	100	200	3000	1,2	9,333	410480
SL 100x200	100	200	6000	1,2	18,666	410490
SL 100x300	100	300	3000	1,2	10,293	410500
SL 100x300	100	300	6000	1,2	20,586	410510
SL 100x400	100	400	3000	1,2	11,198	410520
SL 100x400	100	400	6000	1,2	22,396	410530
SL 100x500	100	500	3000	1,2	12,198	410540
SL 100x500	100	500	6000	1,2	24,396	410550
SL 100x600	100	600	3000	1,2	13,148	410560
SL 100x600	100	600	6000	1,2	26,296	410570
SL 100x200	100	200	3000	1,5	11,666	410580
SL 100x200	100	200	6000	1,5	23,332	410590
SL 100x300	100	300	3000	1,5	12,886	410600
SL 100x300	100	300	6000	1,5	25,772	410610
SL 100x400	100	400	3000	1,5	13,998	410620
SL 100x400	100	400	6000	1,5	27,996	410630
SL 100x500	100	500	3000	1,5	15,248	410640
SL 100x500	100	500	6000	1,5	30,496	410650
SL 100x600	100	600	3000	1,5	16,435	410660
SL 100x600	100	600	6000	1,5	32,870	410670
SL 100x200	100	200	3000	1,8	13,956	410680
SL 100x200	100	200	6000	1,8	27,912	410690
SL 100x300	100	300	3000	1,8	15,436	410700
SL 100x300	100	300	6000	1,8	30,872	410710
SL 100x400	100	400	3000	1,8	16,926	410720
SL 100x400	100	400	6000	1,8	33,852	410730
SL 100x500	100	500	3000	1,8	18,406	410740
SL 100x500	100	500	6000	1,8	36,812	410750
SL 100x600	100	600	3000	1,8	19,886	410760
SL 100x600	100	600	6000	1,8	39,772	410780

Coating types:

- 1) Electro galvanized (2,5-10 mm)
- 2) Zink coating acc.to Sendzimir method (19-20 mm)
- 3) Hot dipped galvanized (50-100 mm)

SLC 50 horizontal bend 90° ladder type cable tray

Type	Height H, mm	Width B, mm	Length L, mm	Thickness S, mm	Weight, kg/quantity	Part number
SLC 50x200	50	600	600	1,2	1,870	410790
SLC 50x300	50	700	700	1,2	2,278	410800
SLC 50x400	50	800	800	1,2	2,692	410810
SLC 50x500	50	900	900	1,2	3,104	410820
SLC 50x600	50	1000	1000	1,2	3,513	410830
SLC 50x200	50	600	600	1,5	2,338	410840
SLC 50x300	50	700	700	1,5	2,848	410850
SLC 50x400	50	800	800	1,5	3,365	410860
SLC 50x500	50	900	900	1,5	3,808	410870
SLC 50x600	50	1000	1000	1,5	4,391	410880
SLC 50x200	50	600	600	1,8	2,805	410890
SLC 50x300	50	700	700	1,8	3,417	410900
SLC 50x400	50	800	800	1,8	4,038	410910
SLC 50x500	50	900	900	1,8	4,656	410920
SLC 50x600	50	1000	1000	1,8	5,270	410930

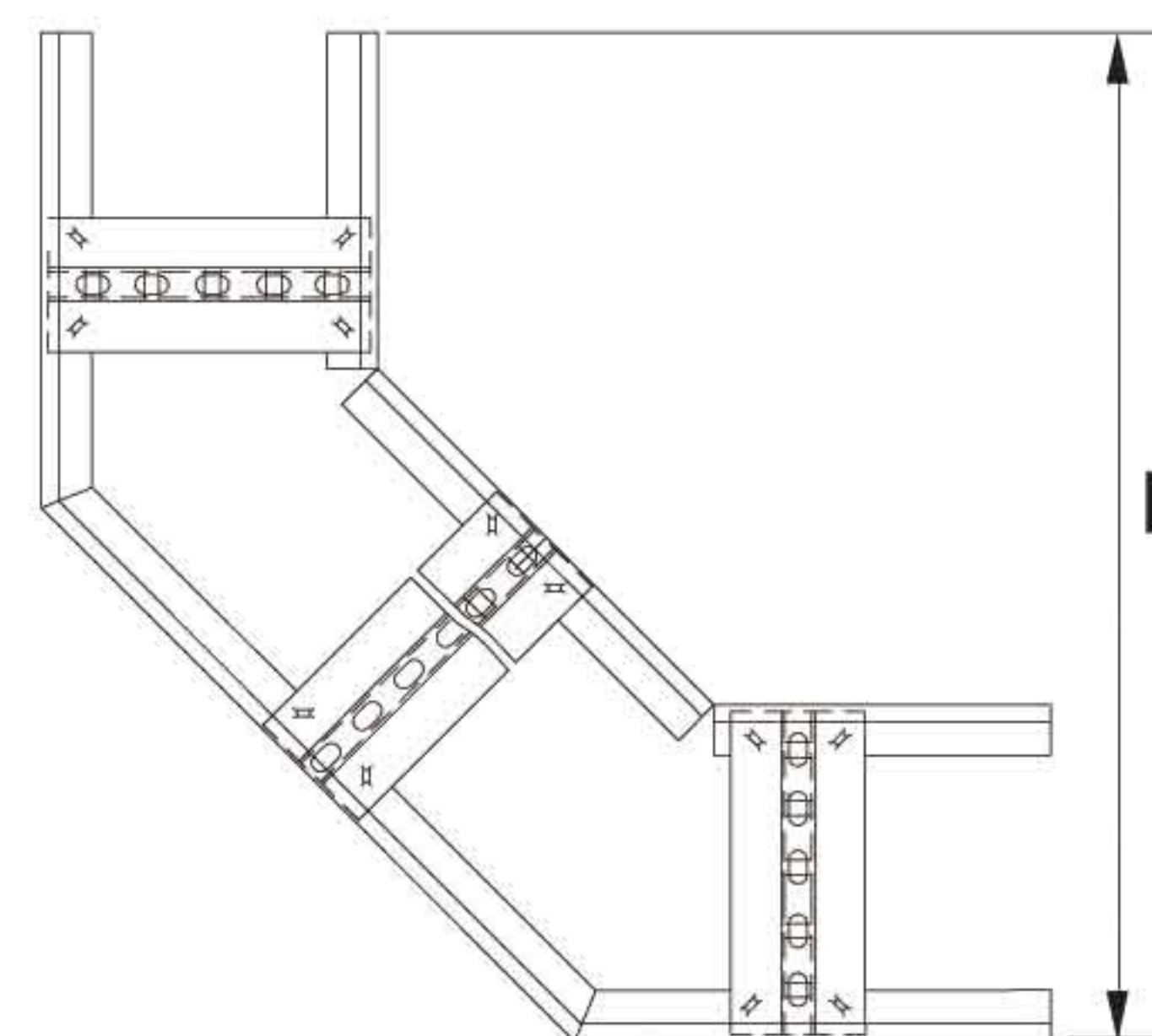

Coating types:

- 1) Electro galvanized (2,5-10 mm)
- 2) Zink coating acc.to Sendzimir method (19-20 mm)
- 3) Hot dipped galvanized (50-100 mm)

SLC 75 horizontal bend 90° ladder type cable tray

Type	Height H, mm	Width B, mm	Length L, mm	Thickness S, mm	Weight, kg/quantity	Part number
SLC 75x200	75	600	600	1,2	2,195	410940
SLC 75x300	75	700	700	1,2	2,637	410950
SLC 75x400	75	800	800	1,2	3,081	410960
SLC 75x500	75	900	900	1,2	3,523	410970
SLC 75x600	75	1000	1000	1,2	3,965	410980
SLC 75x200	75	600	600	1,5	2,743	410990
SLC 75x300	75	700	700	1,5	3,296	420010
SLC 75x400	75	800	800	1,5	3,851	420020
SLC 75x500	75	900	900	1,5	4,403	420030
SLC 75x600	75	1000	1000	1,5	4,956	420040
SLC 75x200	75	600	600	1,8	3,292	420050
SLC 75x300	75	700	700	1,8	3,955	420060
SLC 75x400	75	800	800	1,8	4,621	420070
SLC 75x500	75	900	900	1,8	5,284	420080
SLC 75x600	75	1000	1000	1,8	5,947	420090

Coating types:

- 1) Electro galvanized (2,5-10 mm)
- 2) Zink coating acc.to Sendzimir method (19-20 mm)
- 3) Hot dipped galvanized (50-100 mm)

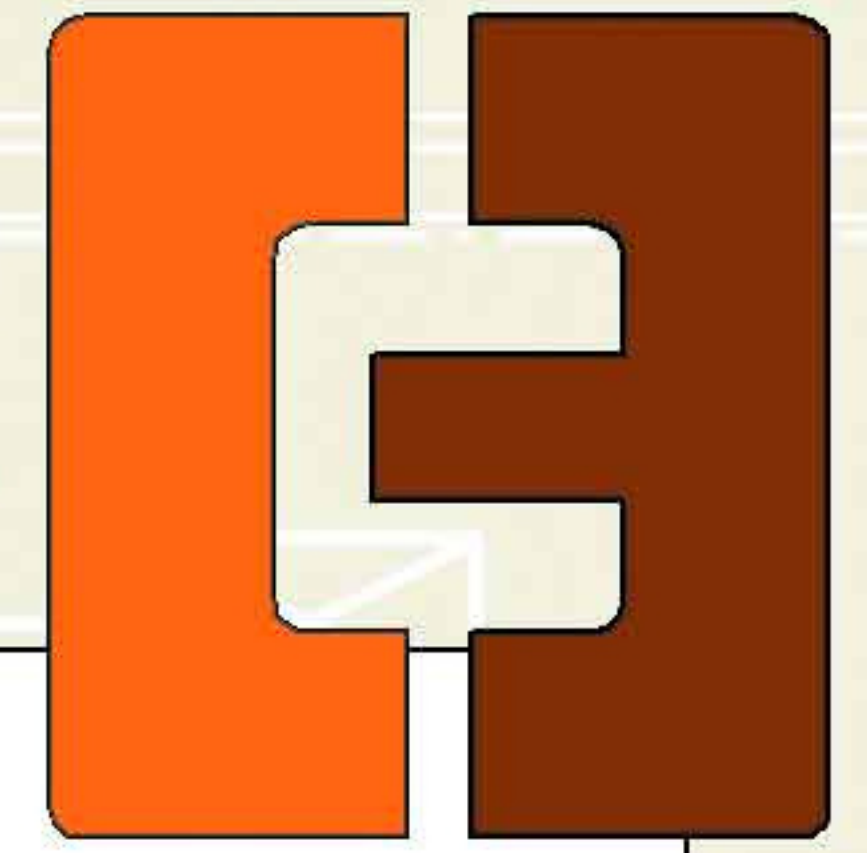

SLC 100 horizontal bend 90° ladder type cable tray

Type	Height H, mm	Width B, mm	Length L, mm	Thickness S, mm	Weight, kg/quantity	Part number
SLC 100x200	100	600	600	1,2	2,656	420100
SLC 100x300	100	700	700	1,2	3,141	420110
SLC 100x400	100	800	800	1,2	3,633	420120
SLC 100x500	100	900	900	1,2	4,121	420130
SLC 100x600	100	1000	1000	1,2	4,607	420140
SLC 100x200	100	600	600	1,5	3,320	420150
SLC 100x300	100	700	700	1,5	3,926	420160
SLC 100x400	100	800	800	1,5	4,541	420170
SLC 100x500	100	900	900	1,5	5,151	420180
SLC 100x600	100	1000	1000	1,5	5,759	420190
SLC 100x200	100	600	600	1,8	3,984	420200
SLC 100x300	100	700	700	1,8	4,712	420210
SLC 100x400	100	800	800	1,8	5,450	420220
SLC 100x500	100	900	900	1,8	6,182	420230
SLC 100x600	100	1000	1000	1,8	6,911	420240

Coating types:

- 1) Electro galvanized (2,5-10 mm)
- 2) Zink coating acc.to Sendzimir method (19-20 mm)
- 3) Hot dipped galvanized (50-100 mm)

SCT 50 horizontal T-piece ladder type cable tray symmetrical

Type	Height H, mm	Width B, mm	Length L, mm	Thickness S, mm	Weight, kg/quantity	Part number
SCT 50x200	50	600	1000	1,2	2,728	420250
SCT 50x300	50	700	1100	1,2	3,178	420260
SCT 50x400	50	800	1200	1,2	4,223	420270
SCT 50x500	50	900	1300	1,2	4,766	420280
SCT 50x600	50	1000	1400	1,2	5,309	420290
SCT 50x200	50	600	1000	1,5	3,177	420300
SCT 50x300	50	700	1100	1,5	3,987	420310
SCT 50x400	50	800	1200	1,5	5,311	420320
SCT 50x500	50	900	1300	1,5	5,999	420330
SCT 50x600	50	1000	1400	1,5	6,687	420340
SCT 50x200	50	600	1000	1,8	4,115	420350
SCT 50x300	50	700	1100	1,8	4,799	420360
SCT 50x400	50	800	1200	1,8	6,389	420370
SCT 50x500	50	900	1300	1,8	7,215	420380
SCT 50x600	50	1000	1400	1,8	8,041	420390

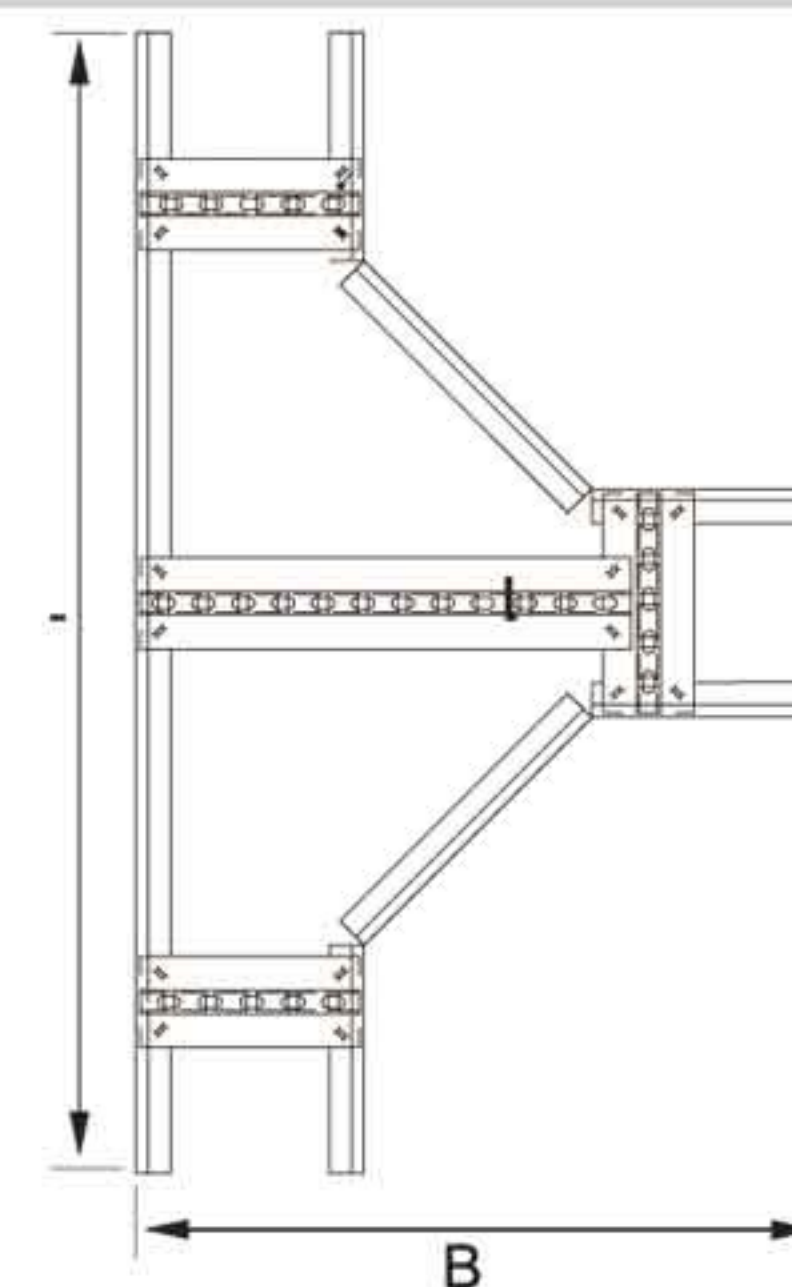

Coating types:

- 1) Electro galvanized (2,5-10 mm)
- 2) Zink coating acc.to Sendzimir method (19-20 mm)
- 3) Hot dipped galvanized (50-100 mm)

SCT 75 horizontal T-piece ladder type cable tray symmetrical

Type	Height H, mm	Width B, mm	Length L, mm	Thickness S, mm	Weight, kg/quantity	Part number
SCT 75x200	75	600	1000	1,2	3,265	420400
SCT 75x300	75	700	1100	1,2	3,738	420410
SCT 75x400	75	800	1200	1,2	4,805	420420
SCT 75x500	75	900	1300	1,2	5,371	420430
SCT 75x600	75	1000	1400	1,2	5,937	420440
SCT 75x200	75	600	1000	1,5	4,100	420450
SCT 75x300	75	700	1100	1,5	4,699	420460
SCT 75x400	75	800	1200	1,5	6,052	420470
SCT 75x500	75	900	1300	1,5	6,769	420480
SCT 75x600	75	1000	1400	1,5	6,673	420490
SCT 75x200	75	600	1000	1,8	4,921	420500
SCT 75x300	75	700	1100	1,8	5,639	420510
SCT 75x400	75	800	1200	1,8	7,263	420520
SCT 75x500	75	900	1300	1,8	8,123	420530
SCT 75x600	75	1000	1400	1,8	8,983	420540

Coating types:

- 1) Electro galvanized (2,5-10 mm)
- 2) Zink coating acc.to Sendzimir method (19-20 mm)
- 3) Hot dipped galvanized (50-100 mm)

SCT 100 horizontal T-piece ladder type cable tray symmetrical

Type	Height H, mm	Width B, mm	Length L, mm	Thickness S, mm	Weight, kg/quantity	Part number
SCT 100x200	100	600	1000	1,2	3,923	420550
SCT 100x300	100	700	1100	1,2	4,423	420560
SCT 100x400	100	800	1200	1,2	5,518	420570
SCT 100x500	100	900	1300	1,2	6,112	420580
SCT 100x600	100	1000	1400	1,2	6,706	420590
SCT 100x200	100	600	1000	1,5	4,923	420600
SCT 100x300	100	700	1100	1,5	5,556	420610
SCT 100x400	100	800	1200	1,5	6,944	420620
SCT 100x500	100	900	1300	1,5	7,696	420630
SCT 100x600	100	1000	1400	1,5	8,447	420640
SCT 100x200	100	600	1000	1,8	5,908	420650
SCT 100x300	100	700	1100	1,8	6,667	420660
SCT 100x400	100	800	1200	1,8	8,333	420670
SCT 100x500	100	900	1300	1,8	9,235	420680
SCT 100x600	100	1000	1400	1,8	10,137	420690

Coating types:

- 1) Electro galvanized (2,5-10 mm)
- 2) Zink coating acc.to Sendzimir method (19-20 mm)
- 3) Hot dipped galvanized (50-100 mm)



**STANDART
ELECTRIC**

SLX 50 cross-over symmetrical ladder type cable tray

Type	Height H, mm	Width B, mm	Length L, mm	Thickness S, mm	Weight, kg/quantity	Part number
SLX 50x200	50	1000	1000	1,2	3,807	420700
SLX 50x300	50	1100	1100	1,2	4,450	420710
SLX 50x400	50	1200	1200	1,2	5,087	420720
SLX 50x500	50	1300	1300	1,2	5,728	420730
SLX 50x600	50	1400	1400	1,2	6,367	420740
SLX 50x200	50	1000	1000	1,5	4,780	420750
SLX 50x300	50	1100	1100	1,5	5,597	420760
SLX 50x400	50	1200	1200	1,5	6,406	420770
SLX 50x500	50	1300	1300	1,5	7,220	420780
SLX 50x600	50	1400	1400	1,5	8,031	420790
SLX 50x200	50	1000	1000	1,8	5,753	420800
SLX 50x300	50	1100	1100	1,8	6,732	420810
SLX 50x400	50	1200	1200	1,8	7,703	420820
SLX 50x500	50	1300	1300	1,8	8,680	420830
SLX 50x600	50	1400	1400	1,8	9,654	420840

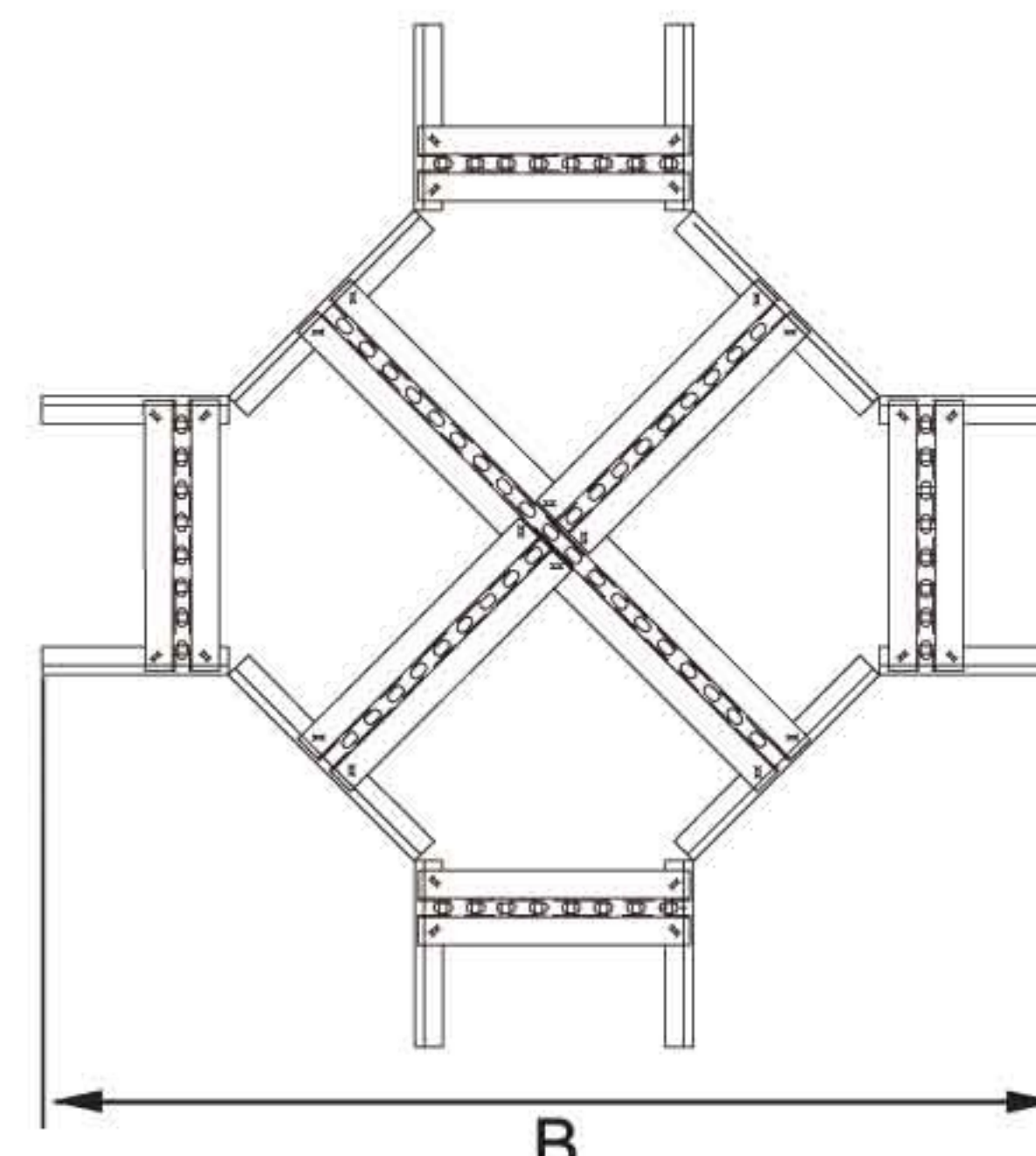

Coating types:

- 1) Electro galvanized (2,5-10 mm)
- 2) Zink coating acc.to Sendzimir method (19-20 mm)
- 3) Hot dipped galvanized (50-100 mm)

SLX 75 cross-over symmetrical ladder type cable tray

Type	Height H, mm	Width B, mm	Length L, mm	Thickness S, mm	Weight, kg/quantity	Part number
SLX 75x200	75	1000	1000	1,2	4,427	420850
SLX 75x300	75	1100	1100	1,2	5,070	420860
SLX 75x400	75	1200	1200	1,2	5,707	420870
SLX 75x500	75	1300	1300	1,2	6,348	420880
SLX 75x600	75	1400	1400	1,2	6,987	420890
SLX 75x200	75	1000	1000	1,5	5,569	420900
SLX 75x300	75	1100	1100	1,5	6,386	420910
SLX 75x400	75	1200	1200	1,5	7,195	420920
SLX 75x500	75	1300	1300	1,5	8,009	420930
SLX 75x600	75	1400	1400	1,5	8,820	420940
SLX 75x200	75	1000	1000	1,8	6,683	420950
SLX 75x300	75	1100	1100	1,8	8,234	420960
SLX 75x400	75	1200	1200	1,8	8,634	420970
SLX 75x500	75	1300	1300	1,8	9,610	420980
SLX 75x600	75	1400	1400	1,8	10,580	420990

Coating types:

- 1) Electro galvanized (2,5-10 mm)
- 2) Zink coating acc.to Sendzimir method (19-20 mm)
- 3) Hot dipped galvanized (50-100 mm)

SLX 100 cross-over symmetrical ladder type cable tray

Type	Height H, mm	Width B, mm	Length L, mm	Thickness S, mm	Weight, kg/quantity	Part number
SLX 100x200	100	1000	1000	1,2	5,187	430010
SLX 100x300	100	1100	1100	1,2	5,829	430020
SLX 100x400	100	1200	1200	1,2	6,467	430030
SLX 100x500	100	1300	1300	1,2	7,107	430040
SLX 100x600	100	1400	1400	1,2	7,747	430050
SLX 100x200	100	1000	1000	1,5	6,519	430060
SLX 100x300	100	1100	1100	1,5	7,335	430070
SLX 100x400	100	1200	1200	1,5	8,144	430080
SLX 100x500	100	1300	1300	1,5	8,958	430090
SLX 100x600	100	1400	1400	1,5	9,770	430100
SLX 100x200	100	1000	1000	1,8	7,822	430110
SLX 100x300	100	1100	1100	1,8	8,802	430120
SLX 100x400	100	1200	1200	1,8	9,773	430130
SLX 100x500	100	1300	1300	1,8	10,750	430140
SLX 100x600	100	1400	1400	1,8	11,720	430150

Coating types:

- 1) Electro galvanized (2,5-10 mm)
- 2) Zink coating acc.to Sendzimir method (19-20 mm)
- 3) Hot dipped galvanized (50-100 mm)

SVI 50 vertical inside bend

Type	Height H, mm	Width B, mm	Length L, mm	Thickness S, mm	Weight, kg/quantity	Part number
SVI 50x200	50	200	560	1,2	2,143	430160
SVI 50x300	50	300	560	1,2	2,472	430170
SVI 50x400	50	400	560	1,2	2,800	430180
SVI 50x500	50	500	560	1,2	3,129	430190
SVI 50x600	50	600	560	1,2	3,458	430200
SVI 50x200	50	200	560	1,5	2,679	430210
SVI 50x300	50	300	560	1,5	3,090	430220
SVI 50x400	50	400	560	1,5	3,500	430230
SVI 50x500	50	500	560	1,5	3,912	430240
SVI 50x600	50	600	560	1,5	4,322	430250
SVI 50x200	50	200	560	1,8	3,215	430260
SVI 50x300	50	300	560	1,8	3,708	430270
SVI 50x400	50	400	560	1,8	4,200	430280
SVI 50x500	50	500	560	1,8	4,694	430290
SVI 50x600	50	600	560	1,8	5,187	430300

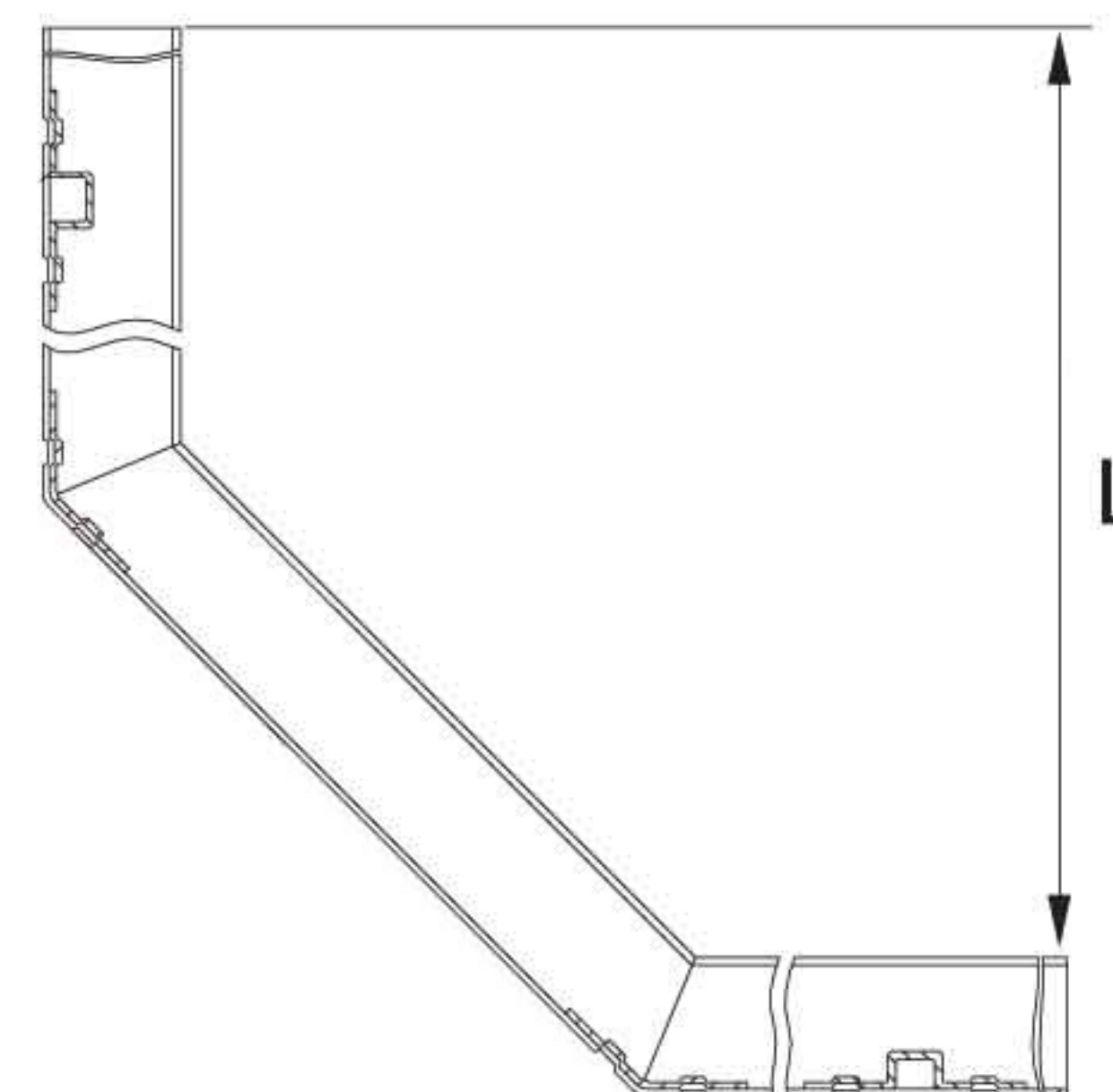

Coating types:

- 1) Electro galvanized (2,5-10 mm)
- 2) Zink coating acc.to Sendzimir method (19-20 mm)
- 3) Hot dipped galvanized (50-100 mm)

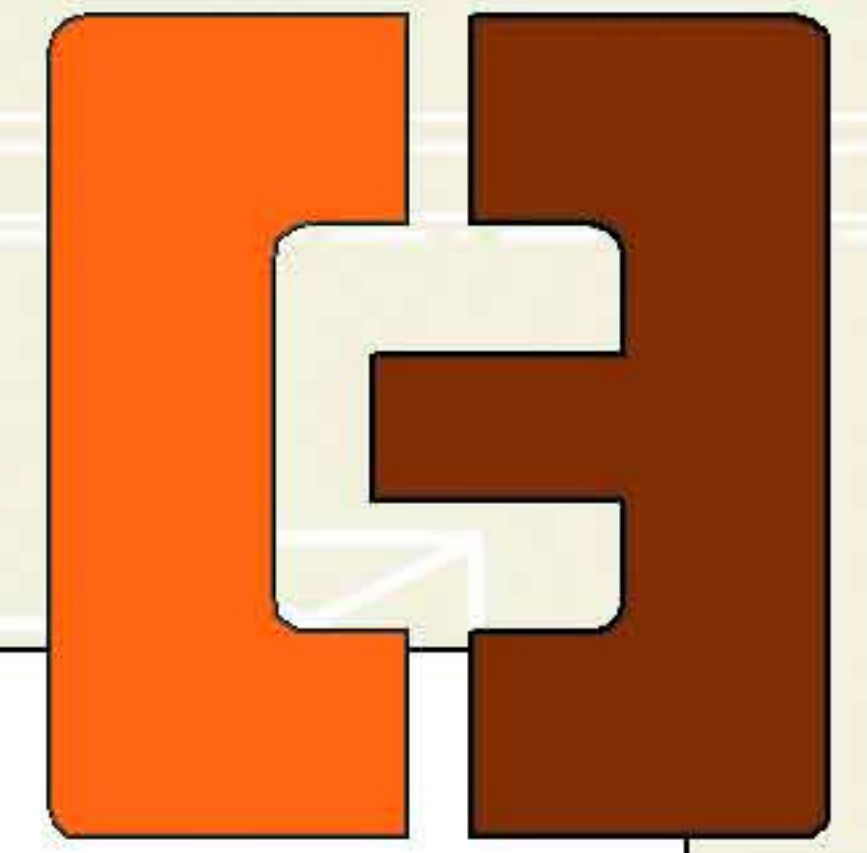

SVI 75 vertical inside bend

Type	Height H, mm	Width B, mm	Length L, mm	Thickness S, mm	Weight, kg/quantity	Part number
SVI 75x200	75	200	560	1,2	2,464	430310
SVI 75x300	75	300	560	1,2	2,792	430320
SVI 75x400	75	400	560	1,2	3,121	430330
SVI 75x500	75	500	560	1,2	3,450	430340
SVI 75x600	75	600	560	1,2	3,778	430350
SVI 75x200	75	200	560	1,5	3,081	430360
SVI 75x300	75	300	560	1,5	3,491	430370
SVI 75x400	75	400	560	1,5	3,902	430380
SVI 75x500	75	500	560	1,5	4,313	430390
SVI 75x600	75	600	560	1,5	4,723	430400
SVI 75x200	75	200	560	1,8	3,697	430410
SVI 75x300	75	300	560	1,8	4,189	430420
SVI 75x400	75	400	560	1,8	4,682	430430
SVI 75x500	75	500	560	1,8	5,176	430440
SVI 75x600	75	600	560	1,8	5,668	430450

Coating types:

- 1) Electro galvanized (2,5-10 mm)
- 2) Zink coating acc.to Sendzimir method (19-20 mm)
- 3) Hot dipped galvanized (50-100 mm)

SVI 100 vertical inside bend

Type	Height H, mm	Width B, mm	Length L, mm	Thickness S, mm	Weight, kg/quantity	Part number
SVI 75x200	100	200	560	1,2	2,988	430460
SVI 75x300	100	300	560	1,2	3,316	430470
SVI 75x400	100	400	560	1,2	3,645	430480
SVI 75x500	100	500	560	1,2	3,974	430490
SVI 75x600	100	600	560	1,2	7,919	430500
SVI 75x200	100	200	560	1,5	3,736	430510
SVI 75x300	100	300	560	1,5	4,145	430520
SVI 75x400	100	400	560	1,5	4,557	430530
SVI 75x500	100	500	560	1,5	4,968	430540
SVI 75x600	100	600	560	1,5	9,900	430550
SVI 75x200	100	200	560	1,8	4,482	430560
SVI 75x300	100	300	560	1,8	4,974	430570
SVI 75x400	100	400	560	1,8	5,468	430580
SVI 75x500	100	500	560	1,8	5,961	430590
SVI 75x600	100	600	560	1,8	11,880	430600

Coating types:

- 1) Electro galvanized (2,5-10 mm)
- 2) Zink coating acc.to Sendzimir method (19-20 mm)
- 3) Hot dipped galvanized (50-100 mm)

SVE 50 vertical outside bend

Type	Height H, mm	Width B, mm	Length L, mm	Thickness S, mm	Weight, kg/quantity	Part number
SVE 50x200	50	200	560	1,2	2,196	430610
SVE 50x300	50	300	560	1,2	2,522	430620
SVE 50x400	50	400	560	1,2	2,850	430630
SVE 50x500	50	500	560	1,2	3,178	430640
SVE 50x600	50	600	560	1,2	3,504	430650
SVE 50x200	50	200	560	1,5	2,745	430660
SVE 50x300	50	300	560	1,5	3,153	430670
SVE 50x400	50	400	560	1,5	3,563	430680
SVE 50x500	50	500	560	1,5	3,973	430690
SVE 50x600	50	600	560	1,5	4,380	430700
SVE 50x200	50	200	560	1,8	3,294	430710
SVE 50x300	50	300	560	1,8	3,783	430720
SVE 50x400	50	400	560	1,8	4,275	430730
SVE 50x500	50	500	560	1,8	4,767	430740
SVE 50x600	50	600	560	1,8	5,256	430750

Coating types:

- 1) Electro galvanized (2,5-10 mm)
- 2) Zink coating acc.to Sendzimir method (19-20 mm)
- 3) Hot dipped galvanized (50-100 mm)

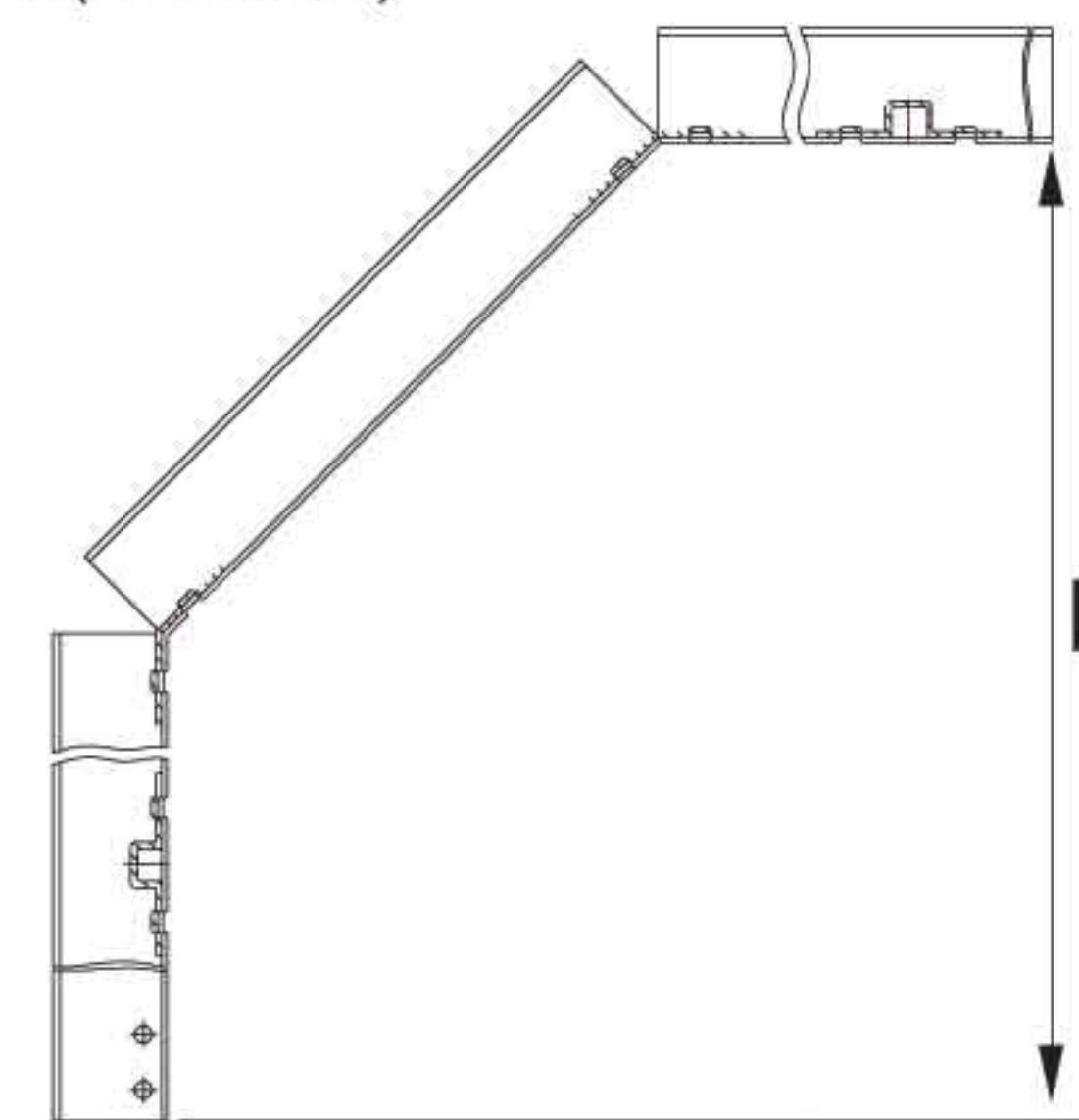

SVE 75 vertical outside bend

Type	Height H, mm	Width B, mm	Length L, mm	Thickness S, mm	Weight, kg/quantity	Part number
SVE 75x200	75	200	560	1,2	2,543	430760
SVE 75x300	75	300	560	1,2	2,871	430770
SVE 75x400	75	400	560	1,2	3,200	430780
SVE 75x500	75	500	560	1,2	3,530	430790
SVE 75x600	75	600	560	1,2	3,857	430800
SVE 75x200	75	200	560	1,5	3,179	430810
SVE 75x300	75	300	560	1,5	3,589	430820
SVE 75x400	75	400	560	1,5	4,000	430830
SVE 75x500	75	500	560	1,5	4,412	430840
SVE 75x600	75	600	560	1,5	4,822	430850
SVE 75x200	75	200	560	1,8	3,815	430860
SVE 75x300	75	300	560	1,8	4,307	430870
SVE 75x400	75	400	560	1,8	4,800	430880
SVE 75x500	75	500	560	1,8	5,294	430890
SVE 75x600	75	600	560	1,8	5,786	430900

Coating types:

- 1) Electro galvanized (2,5-10 mm)
- 2) Zink coating acc.to Sendzimir method (19-20 mm)
- 3) Hot dipped galvanized (50-100 mm)



**STANDART
ELECTRIC**

SVE 100 vertical outside bend

Type	Height H, mm	Width B, mm	Length L, mm	Thickness S, mm	Weight, kg/quantity	Part number
SVE 100x200	100	200	560	1,2	3,077	430910
SVE 100x300	100	300	560	1,2	3,400	430920
SVE 100x400	100	400	560	1,2	3,731	430930
SVE 100x500	100	500	560	1,2	4,059	430940
SVE 100x600	100	600	560	1,2	4,385	430950
SVE 100x200	100	200	560	1,5	3,846	430960
SVE 100x300	100	300	560	1,5	4,250	430970
SVE 100x400	100	400	560	1,5	4,676	430980
SVE 100x500	100	500	560	1,5	5,073	430990
SVE 100x600	100	600	560	1,5	5,481	440010
SVE 100x200	100	200	560	1,8	4,615	440020
SVE 100x300	100	300	560	1,8	5,100	440030
SVE 100x400	100	400	560	1,8	5,611	440040
SVE 100x500	100	500	560	1,8	6,088	440050
SVE 100x600	100	600	560	1,8	6,577	440060

Coating types:

- 1) Electro galvanized (2,5-10 mm)
- 2) Zink coating acc.to Sendzimir method (19-20 mm)
- 3) Hot dipped galvanized (50-100 mm)

SVS 50 T-adapter straight

Type	Height H, mm	Width B, mm	Width B1, mm	Length L, mm	Thickness S, mm	Weight, kg/quantity	Part number
SVS 50x300x200	50	300	200	605	1,2	1,413	440070
SVS 50x400x200	50	400	200	622	1,2	1,535	440080
SVS 50x400x300	50	400	300	605	1,2	1,600	440090
SVS 50x500x200	50	500	200	647	1,2	1,667	440100
SVS 50x500x300	50	500	300	622	1,2	1,722	440110
SVS 50x500x400	50	500	400	605	1,2	1,788	440120
SVS 50x600x200	50	600	200	677	1,2	1,808	440130
SVS 50x600x300	50	600	300	647	1,2	1,853	440140
SVS 50x600x400	50	600	400	622	1,2	1,909	440150
SVS 50x600x500	50	600	500	605	1,2	1,975	440160
SVS 50x300x200	50	300	200	605	1,5	1,766	440170
SVS 50x400x200	50	400	200	622	1,5	1,919	440180
SVS 50x400x300	50	400	300	605	1,5	2,000	440190
SVS 50x500x200	50	500	200	647	1,5	2,084	440200
SVS 50x500x300	50	500	300	622	1,5	2,153	440210
SVS 50x500x400	50	500	400	605	1,5	2,235	440220
SVS 50x600x200	50	600	200	677	1,5	2,260	440230
SVS 50x600x300	50	600	300	647	1,5	2,316	440240
SVS 50x600x400	50	600	400	622	1,5	2,386	440250
SVS 50x600x500	50	600	500	605	1,5	2,469	440260
SVS 50x300x200	50	300	200	605	1,8	2,119	440270
SVS 50x400x200	50	400	200	622	1,8	2,300	440280
SVS 50x400x300	50	400	300	605	1,8	2,401	440290
SVS 50x500x200	50	500	200	647	1,8	2,500	440300
SVS 50x500x300	50	500	300	622	1,8	2,583	440310
SVS 50x500x400	50	500	400	605	1,8	2,682	440320
SVS 50x600x200	50	600	200	677	1,8	2,712	440330
SVS 50x600x300	50	600	300	647	1,8	2,779	440340
SVS 50x600x400	50	600	400	622	1,8	2,863	440350
SVS 50x600x500	50	600	500	605	1,8	2,962	440360

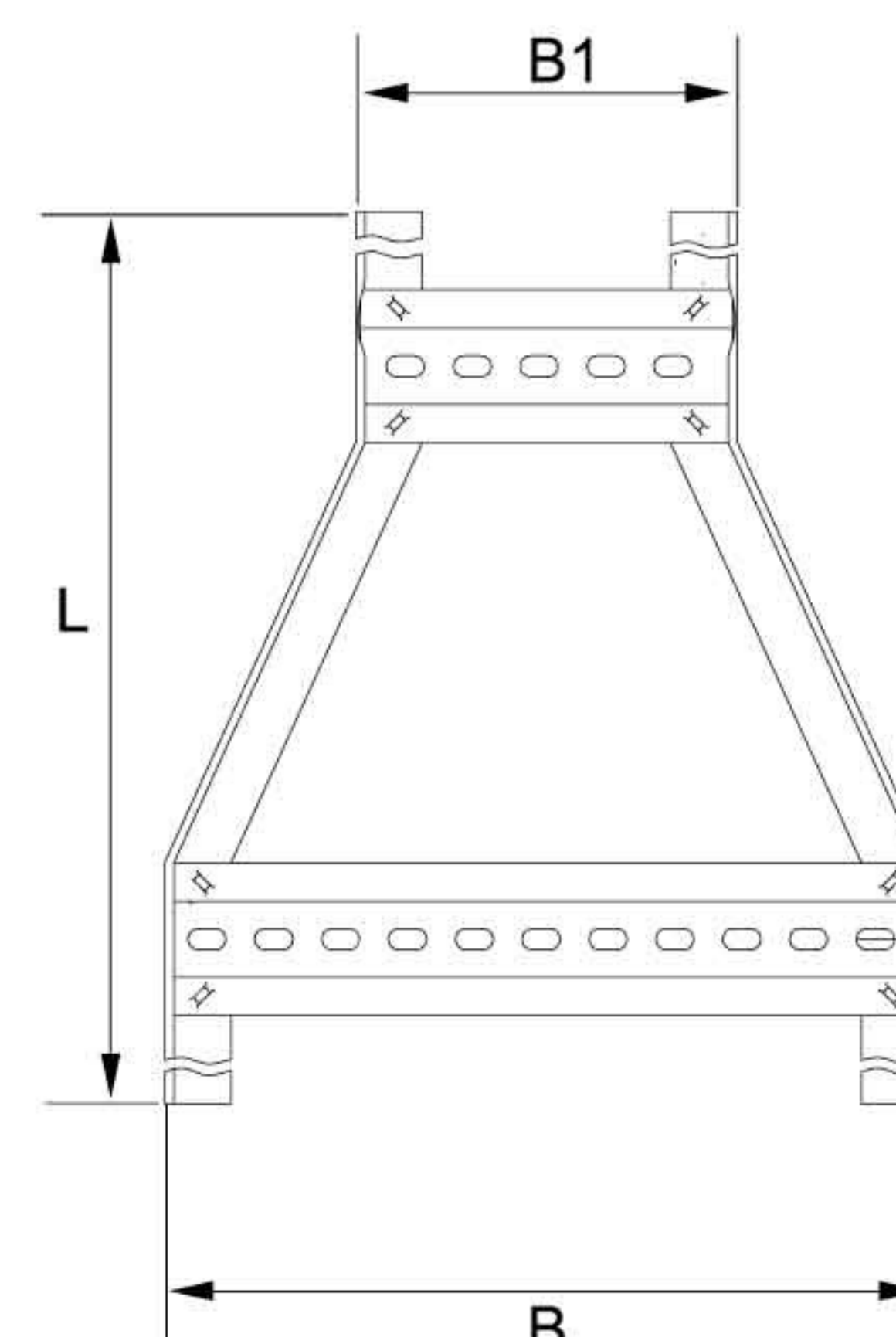

Coating types:

- 1) Electro galvanized (2,5-10 mm)
- 2) Zink coating acc.to Sendzimir method (19-20 mm)
- 3) Hot dipped galvanized (50-100 mm)

SVS 75 T-adapter straight

Type	Height H, mm	Width B, mm	Width B1, mm	Length L, mm	Thickness S, mm	Weight, kg/quantity	Part number
SVS 75x300x200	75	300	200	605	1,2	1,641	440370
SVS 75x400x200	75	400	200	622	1,2	1,767	440380
SVS 75x400x300	75	400	300	605	1,2	1,828	440390
SVS 75x500x200	75	500	200	647	1,2	1,911	440400
SVS 75x500x300	75	500	300	622	1,2	1,954	440410
SVS 75x500x400	75	500	400	605	1,2	2,016	440420
SVS 75x600x200	75	600	200	677	1,2	2,062	440430
SVS 75x600x300	75	600	300	647	1,2	2,097	440440
SVS 75x600x400	75	600	400	622	1,2	2,141	440450
SVS 75x600x500	75	600	500	605	1,2	2,203	440460
SVS 75x300x200	75	300	200	605	1,5	2,051	440470
SVS 75x400x200	75	400	200	622	1,5	2,208	440480
SVS 75x400x300	75	400	300	605	1,5	2,285	440490
SVS 75x500x200	75	500	200	647	1,5	2,388	440500
SVS 75x500x300	75	500	300	622	1,5	2,442	440510
SVS 75x500x400	75	500	400	605	1,5	2,520	440520
SVS 75x600x200	75	600	200	677	1,5	2,577	440530
SVS 75x600x300	75	600	300	647	1,5	2,621	440540
SVS 75x600x400	75	600	400	622	1,5	2,676	440550
SVS 75x600x500	75	600	500	605	1,5	2,753	440560

Coating types:

- 1) Electro galvanized (2,5-10 mm)
- 2) Zink coating acc.to Sendzimir method (19-20 mm)
- 3) Hot dipped galvanized (50-100 mm)

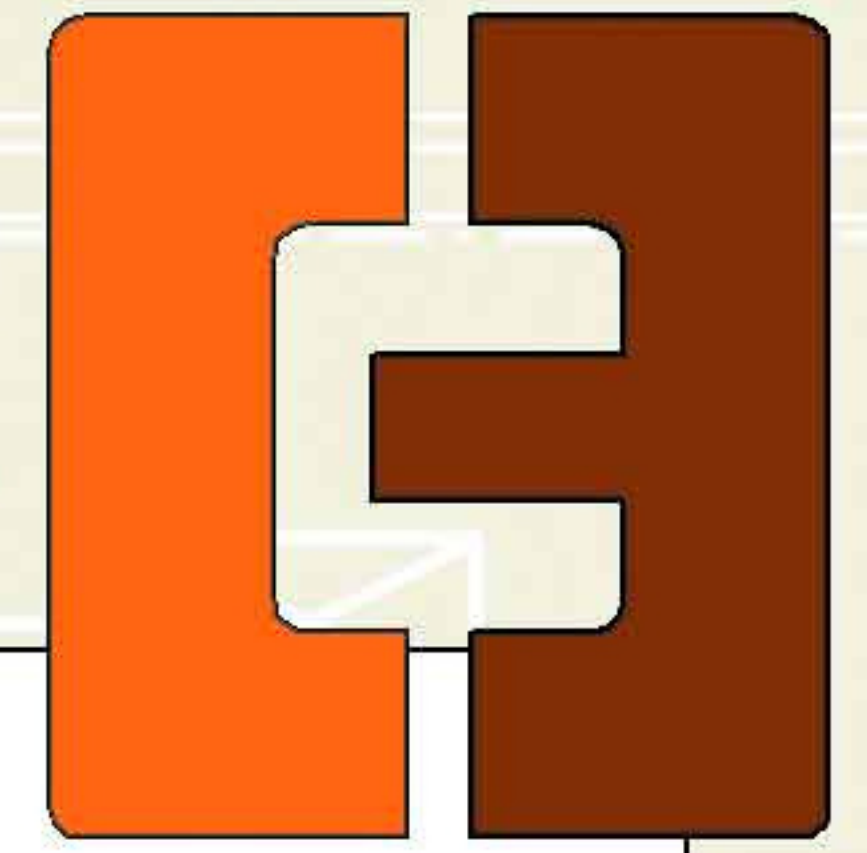

SVS 75 T-adapter straight

Type	Height H, mm	Width B, mm	Width B1, mm	Length L, mm	Thickness S, mm	Weight, kg/quantity	Part number
SVS 75x300x200	75	300	200	605	1,8	2,461	440570
SVS 75x400x200	75	400	200	622	1,8	2,650	440580
SVS 75x400x300	75	400	300	605	1,8	2,742	440590
SVS 75x500x200	75	500	200	647	1,8	2,866	440600
SVS 75x500x300	75	500	300	622	1,8	2,931	440610
SVS 75x500x400	75	500	400	605	1,8	3,024	440620
SVS 75x600x200	75	600	200	677	1,8	3,093	440630
SVS 75x600x300	75	600	300	647	1,8	3,145	440640
SVS 75x600x400	75	600	400	622	1,8	3,211	440650
SVS 75x600x500	75	600	500	605	1,8	3,304	440660

Coating types:

- 1) Electro galvanized (2,5-10 mm)
- 2) Zink coating acc.to Sendzimir method (19-20 mm)
- 3) Hot dipped galvanized (50-100 mm)

SVS 100 T-adapter straight

Type	Height H, mm	Width B, mm	Width B1, mm	Length L, mm	Thickness S, mm	Weight, kg/quantity	Part number
SVS 100x300x200	100	300	200	605	1,2	1,977	440670
SVS 100x400x200	100	400	200	622	1,2	2,113	440680
SVS 100x400x300	100	400	300	605	1,2	2,164	440690
SVS 100x500x200	100	500	200	647	1,2	2,271	440700
SVS 100x500x300	100	500	300	622	1,2	2,300	440710
SVS 100x500x400	100	500	400	605	1,2	2,352	440720
SVS 100x600x200	100	600	200	677	1,2	2,438	440730
SVS 100x600x300	100	600	300	647	1,2	2,457	440740
SVS 100x600x400	100	600	400	622	1,2	2,487	440750
SVS 100x600x500	100	600	500	605	1,2	2,539	440760
SVS 100x300x200	100	300	200	605	1,5	2,471	440770
SVS 100x400x200	100	400	200	622	1,5	2,641	440780
SVS 100x400x300	100	400	300	605	1,5	2,705	440790
SVS 100x500x200	100	500	200	647	1,5	2,838	440800
SVS 100x500x300	100	500	300	622	1,5	2,875	440810
SVS 100x500x400	100	500	400	605	1,5	2,940	440820
SVS 100x600x200	100	600	200	677	1,5	3,047	440830
SVS 100x600x300	100	600	300	647	1,5	3,071	440840
SVS 100x600x400	100	600	400	622	1,5	3,108	440850
SVS 100x600x500	100	600	500	605	1,5	3,173	440860
SVS 100x300x200	100	300	200	605	1,8	2,965	440870
SVS 100x400x200	100	400	200	622	1,8	3,169	440880
SVS 100x400x300	100	400	300	605	1,8	3,246	440890
SVS 100x500x200	100	500	200	647	1,8	3,406	440900
SVS 100x500x300	100	500	300	622	1,8	3,450	440910
SVS 100x500x400	100	500	400	605	1,8	3,528	440920
SVS 100x600x200	100	600	200	677	1,8	3,657	440930
SVS 100x600x300	100	600	300	647	1,8	3,685	440940
SVS 100x600x400	100	600	400	622	1,8	3,730	440950
SVS 100x600x500	100	600	500	605	1,8	3,808	440960

Coating types:

- 1) Electro galvanized (2,5-10 mm)
- 2) Zink coating acc.to Sendzimir method (19-20 mm)
- 3) Hot dipped galvanized (50-100 mm)

SVPL 50 T-adapter left hand

Type	Height H, mm	Width B, mm	Width B1, mm	Length L, mm	Thickness S, mm	Weight, kg/quantity	Part number
SVPL 50x300x200	50	300	200	622	1,2	1,423	440970
SVPL 50x400x200	50	400	200	677	1,2	1,560	440980
SVPL 50x400x300	50	400	300	622	1,2	1,610	440990
SVPL 50x500x200	50	500	200	752	1,2	1,713	450010
SVPL 50x500x300	50	500	300	677	1,2	1,747	450020
SVPL 50x500x400	50	500	400	622	1,2	1,798	450030
SVPL 50x600x200	50	600	200	677	1,2	1,747	450040
SVPL 50x600x300	50	600	300	752	1,2	1,899	450050
SVPL 50x600x400	50	600	400	677	1,2	1,934	450060
SVPL 50x600x500	50	600	500	622	1,2	1,985	450070
SVPL 50x300x200	50	300	200	622	1,5	1,779	450080
SVPL 50x400x200	50	400	200	677	1,5	1,950	450090
SVPL 50x400x300	50	400	300	622	1,5	2,013	450100
SVPL 50x500x200	50	500	200	752	1,5	2,141	450110
SVPL 50x500x300	50	500	300	677	1,5	2,184	450120
SVPL 50x500x400	50	500	400	622	1,5	2,248	450130
SVPL 50x600x200	50	600	200	677	1,5	2,184	450140
SVPL 50x600x300	50	600	300	752	1,5	2,374	450150
SVPL 50x600x400	50	600	400	677	1,5	2,418	450160
SVPL 50x600x500	50	600	500	622	1,5	2,481	450170
SVPL 50x300x200	50	300	200	622	1,8	2,135	450180
SVPL 50x400x200	50	400	200	677	1,8	2,340	450190
SVPL 50x400x300	50	400	300	622	1,8	2,415	450200
SVPL 50x500x200	50	500	200	752	1,8	2,569	450210
SVPL 50x500x300	50	500	300	677	1,8	2,621	450220
SVPL 50x500x400	50	500	400	622	1,8	2,696	450230
SVPL 50x600x200	50	600	200	677	1,8	2,620	450240
SVPL 50x600x300	50	600	300	752	1,8	2,620	450250
SVPL 50x600x400	50	600	400	677	1,8	2,900	450260
SVPL 50x600x500	50	600	500	622	1,8	2,977	450270

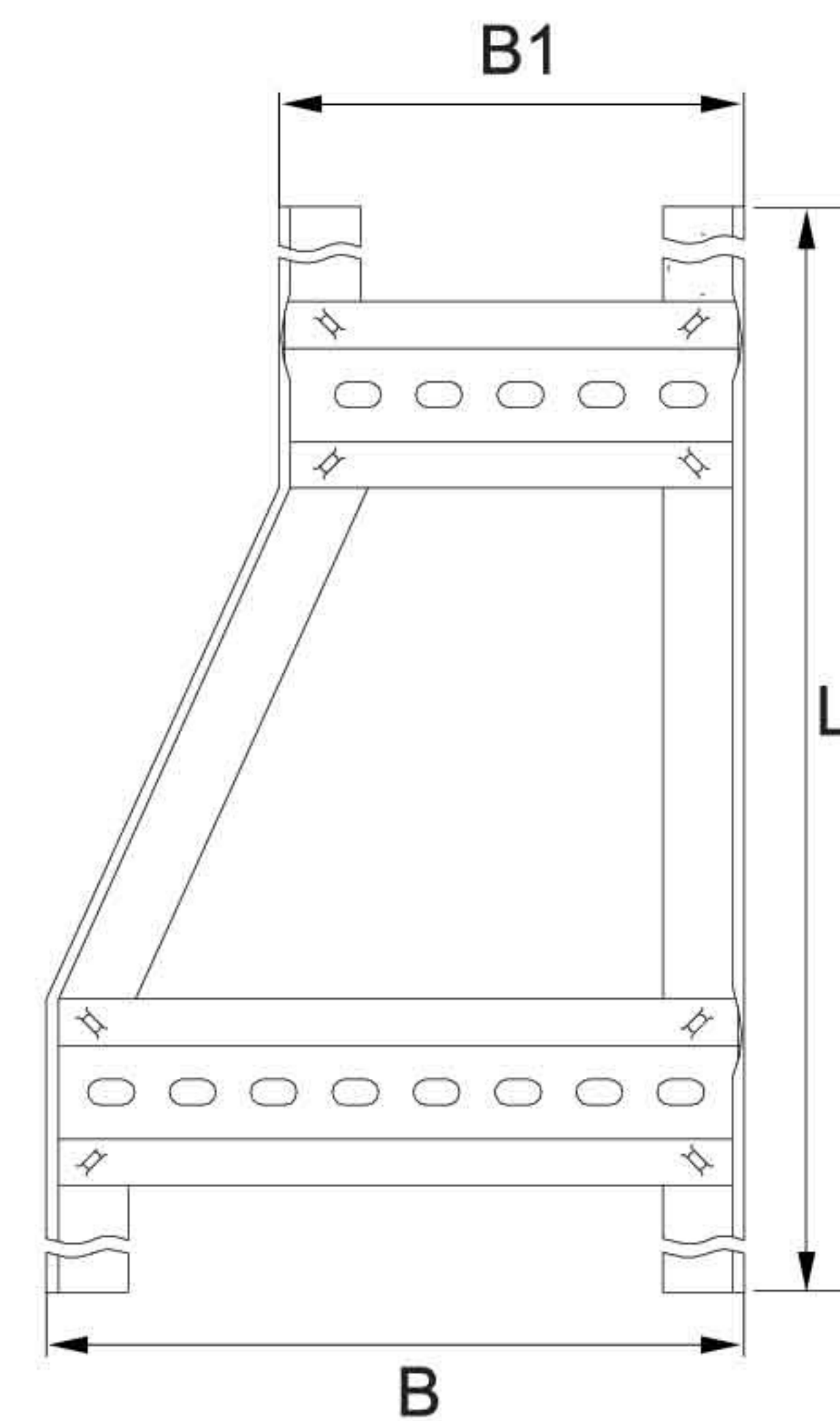

Coating types:

- 1) Electro galvanized (2,5-10 mm)
- 2) Zink coating acc.to Sendzimir method (19-20 mm)
- 3) Hot dipped galvanized (50-100 mm)



SVPL 75 T-adapter left hand

Type	Height H, mm	Width B, mm	Width B1, mm	Length L, mm	Thickness S, mm	Weight, kg/quantity	Part number
SVPL 75x300x200	75	300	200	622	1,2	1,652	450280
SVPL 75x400x200	75	400	200	677	1,2	1,800	450290
SVPL 75x400x300	75	400	300	622	1,2	1,839	450300
SVPL 75x500x200	75	500	200	752	1,2	1,967	450310
SVPL 75x500x300	75	500	300	677	1,2	1,987	450320
SVPL 75x500x400	75	500	400	622	1,2	2,027	450330
SVPL 75x600x200	75	600	200	677	1,2	1,987	450340
SVPL 75x600x300	75	600	300	752	1,2	2,153	450350
SVPL 75x600x400	75	600	400	677	1,2	2,174	450360
SVPL 75x600x500	75	600	500	622	1,2	2,214	450370
SVPL 75x300x200	75	300	200	622	1,5	2,065	450380
SVPL 75x400x200	75	400	200	677	1,5	2,250	450390
SVPL 75x400x300	75	400	300	622	1,5	2,298	450400
SVPL 75x500x200	75	500	200	752	1,5	2,458	450410
SVPL 75x500x300	75	500	300	677	1,5	2,483	450420
SVPL 75x500x400	75	500	400	622	1,5	2,533	450430
SVPL 75x600x200	75	600	200	677	1,5	2,483	450440
SVPL 75x600x300	75	600	300	752	1,5	2,691	450450
SVPL 75x600x400	75	600	400	677	1,5	2,717	450460
SVPL 75x600x500	75	600	500	622	1,5	2,767	450470
SVPL 75x300x200	75	300	200	622	1,8	2,478	450480
SVPL 75x400x200	75	400	200	677	1,8	2,700	450490
SVPL 75x400x300	75	400	300	622	1,8	2,758	450500
SVPL 75x500x200	75	500	200	752	1,8	2,905	450510
SVPL 75x500x300	75	500	300	677	1,8	2,980	450520
SVPL 75x500x400	75	500	400	622	1,8	3,040	450530
SVPL 75x600x200	75	600	200	677	1,8	2,980	450540
SVPL 75x600x300	75	600	300	752	1,8	3,230	450550
SVPL 75x600x400	75	600	400	677	1,8	3,261	450560
SVPL 75x600x500	75	600	500	622	1,8	3,321	450570

Coating types:

- 1) Electro galvanized (2,5-10 mm)
- 2) Zink coating acc.to Sendzimir method (19-20 mm)
- 3) Hot dipped galvanized (50-100 mm)

SVPL 100 T-adapter left hand

Type	Height H, mm	Width B, mm	Width B1, mm	Length L, mm	Thickness S, mm	Weight, kg/quantity	Part number
SVPL 100x300x200	100	300	200	622	1,2	1,992	450580
SVPL 100x400x200	100	400	200	677	1,2	2,155	450590
SVPL 100x400x300	100	400	300	622	1,2	2,179	450600
SVPL 100x500x200	100	500	200	752	1,2	2,343	450610
SVPL 100x500x300	100	500	300	677	1,2	2,342	450620
SVPL 100x500x400	100	500	400	622	1,2	2,367	450630
SVPL 100x600x200	100	600	200	677	1,2	2,342	450640
SVPL 100x600x300	100	600	300	752	1,2	2,527	450650
SVPL 100x600x400	100	600	400	677	1,2	2,529	450660
SVPL 100x600x500	100	600	500	622	1,2	2,554	450670
SVPL 100x300x200	100	300	200	622	1,5	2,490	450680
SVPL 100x400x200	100	400	200	677	1,5	2,693	450690
SVPL 100x400x300	100	400	300	622	1,5	2,723	450700
SVPL 100x500x200	100	500	200	752	1,5	2,928	450710
SVPL 100x500x300	100	500	300	677	1,5	2,927	450720
SVPL 100x500x400	100	500	400	622	1,5	2,958	450730
SVPL 100x600x200	100	600	200	677	1,5	2,927	450740
SVPL 100x600x300	100	600	300	752	1,5	3,158	450750
SVPL 100x600x400	100	600	400	677	1,5	3,161	450760
SVPL 100x600x500	100	600	500	622	1,5	3,192	450770
SVPL 100x300x200	100	300	200	622	1,8	2,988	450780
SVPL 100x400x200	100	400	200	677	1,8	3,232	450790
SVPL 100x400x300	100	400	300	622	1,8	3,268	450800
SVPL 100x500x200	100	500	200	752	1,8	3,514	450810
SVPL 100x500x300	100	500	300	677	1,8	3,513	450820
SVPL 100x500x400	100	500	400	622	1,8	3,550	450830
SVPL 100x600x200	100	600	200	677	1,8	3,513	450840
SVPL 100x600x300	100	600	300	752	1,8	3,790	450850
SVPL 100x600x400	100	600	400	677	1,8	3,793	450860
SVPL 100x600x500	100	600	500	622	1,8	3,831	450870

Coating types:

- 1) Electro galvanized (2,5-10 mm)
- 2) Zink coating acc.to Sendzimir method (19-20 mm)
- 3) Hot dipped galvanized (50-100 mm)

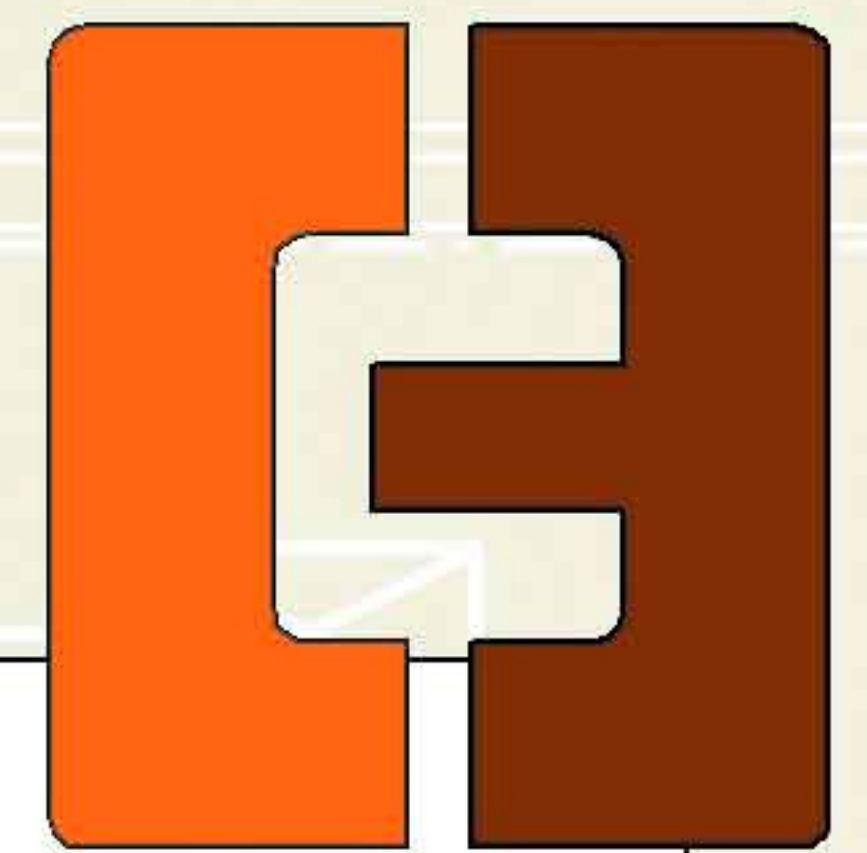

SVPR 50 T-adapter right hand

Type	Height H, mm	Width B, mm	Width B1, mm	Length L, mm	Thickness S, mm	Weight, kg/quantity	Part number
SVPR 50x300x200	50	300	200	622	1,2	1,423	450880
SVPR 50x400x200	50	400	200	677	1,2	1,560	450890
SVPR 50x400x300	50	400	300	622	1,2	1,610	450900
SVPR 50x500x200	50	500	200	752	1,2	1,713	450910
SVPR 50x500x300	50	500	300	677	1,2	1,747	450920
SVPR 50x500x400	50	500	400	622	1,2	1,798	450930
SVPR 50x600x200	50	600	200	677	1,2	1,747	450940
SVPR 50x600x300	50	600	300	752	1,2	1,899	450950
SVPR 50x600x400	50	600	400	677	1,2	1,934	450960
SVPR 50x600x500	50	600	500	622	1,2	1,985	450970
SVPR 50x300x200	50	300	200	622	1,5	1,779	450980
SVPR 50x400x200	50	400	200	677	1,5	1,950	450990
SVPR 50x400x300	50	400	300	622	1,5	2,013	460010
SVPR 50x500x200	50	500	200	752	1,5	2,141	460020
SVPR 50x500x300	50	500	300	677	1,5	2,184	460030
SVPR 50x500x400	50	500	400	622	1,5	2,248	460040
SVPR 50x600x200	50	600	200	677	1,5	2,184	460050
SVPR 50x600x300	50	600	300	752	1,5	2,374	460060
SVPR 50x600x400	50	600	400	677	1,5	2,418	460070
SVPR 50x600x500	50	600	500	622	1,5	2,481	460080
SVPR 50x300x200	50	300	200	622	1,8	2,135	460090
SVPR 50x400x200	50	400	200	677	1,8	2,340	460100
SVPR 50x400x300	50	400	300	622	1,8	2,415	460110
SVPR 50x500x200	50	500	200	752	1,8	2,569	460120
SVPR 50x500x300	50	500	300	677	1,8	2,621	460130
SVPR 50x500x400	50	500	400	622	1,8	2,696	460140
SVPR 50x600x200	50	600	200	677	1,8	2,620	460150
SVPR 50x600x300	50	600	300	752	1,8	2,848	460160
SVPR 50x600x400	50	600	400	677	1,8	2,900	460170
SVPR 50x600x500	50	600	500	622	1,8	2,977	460180

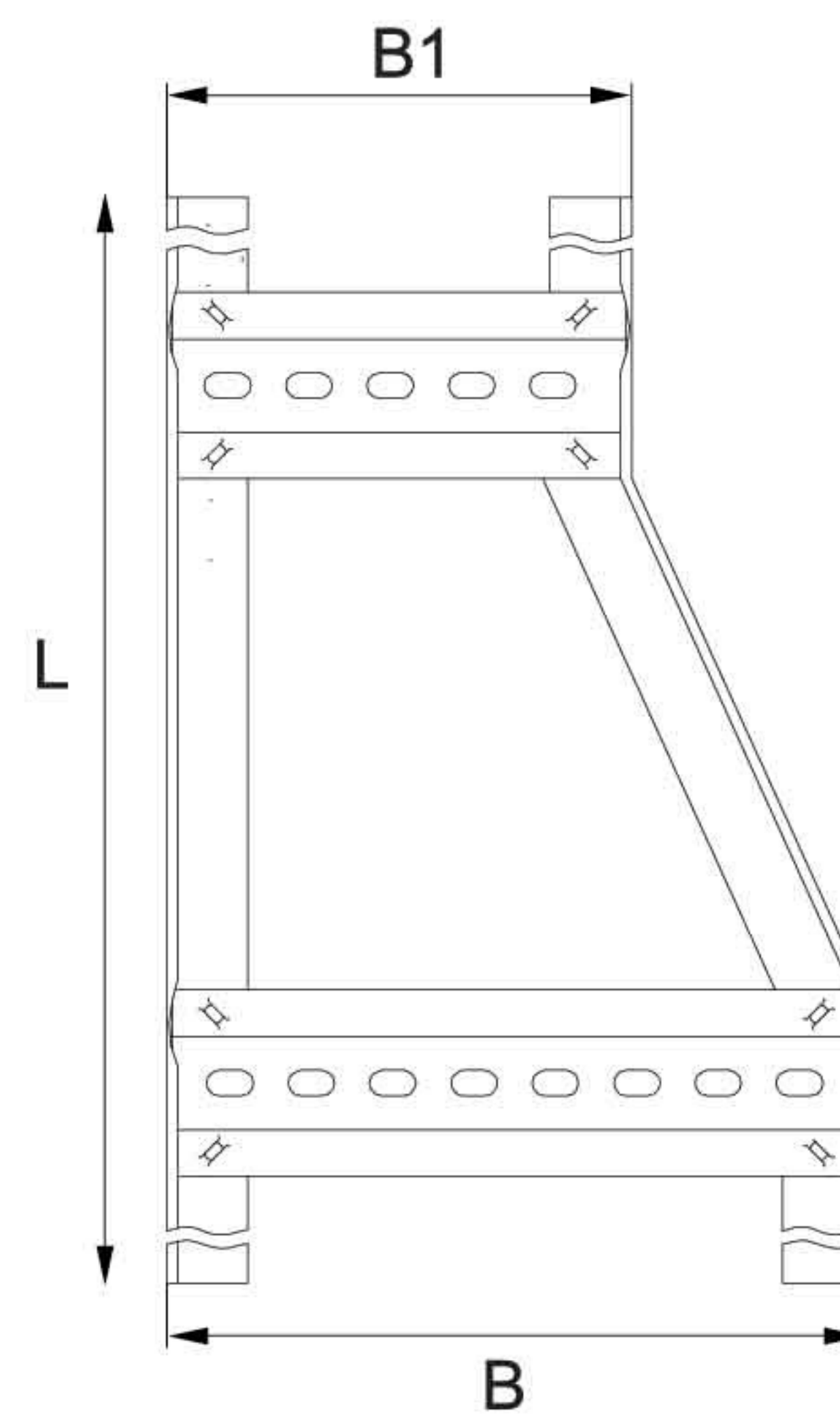

Coating types:

- 1) Electro galvanized (2,5-10 mm)
- 2) Zink coating acc.to Sendzimir method (19-20 mm)
- 3) Hot dipped galvanized (50-100 mm)

SVPR 75 T-adapter right hand

Type	Height H, mm	Width B, mm	Width B1, mm	Length L, mm	Thickness S, mm	Weight, kg/quantity	Part number
SVPR 75x300x200	75	300	200	622	1,2	1,652	460190
SVPR 75x400x200	75	400	200	677	1,2	1,800	460200
SVPR 75x400x300	75	400	300	622	1,2	1,839	460210
SVPR 75x500x200	75	500	200	752	1,2	1,967	460220
SVPR 75x500x300	75	500	300	677	1,2	1,987	460230
SVPR 75x500x400	75	500	400	622	1,2	2,027	460240
SVPR 75x600x200	75	600	200	677	1,2	1,987	460250
SVPR 75x600x300	75	600	300	752	1,2	2,153	460260
SVPR 75x600x400	75	600	400	677	1,2	2,174	460270
SVPR 75x600x500	75	600	500	622	1,2	2,214	460280
SVPR 75x300x200	75	300	200	622	1,5	2,065	460290
SVPR 75x400x200	75	400	200	677	1,5	2,250	460300
SVPR 75x400x300	75	400	300	622	1,5	2,298	460310
SVPR 75x500x200	75	500	200	752	1,5	2,458	460320
SVPR 75x500x300	75	500	300	677	1,5	2,483	460330
SVPR 75x500x400	75	500	400	622	1,5	2,533	460340
SVPR 75x600x200	75	600	200	677	1,5	2,483	460350
SVPR 75x600x300	75	600	300	752	1,5	2,691	460360
SVPR 75x600x400	75	600	400	677	1,5	2,717	460370
SVPR 75x600x500	75	600	500	622	1,5	2,767	460380
SVPR 75x300x200	75	300	200	622	1,8	2,478	460390
SVPR 75x400x200	75	400	200	677	1,8	2,700	460400
SVPR 75x400x300	75	400	300	622	1,8	2,758	460410
SVPR 75x500x200	75	500	200	752	1,8	2,905	460420
SVPR 75x500x300	75	500	300	677	1,8	2,980	460430
SVPR 75x500x400	75	500	400	622	1,8	3,040	460440
SVPR 75x600x200	75	600	200	677	1,8	2,980	460450
SVPR 75x600x300	75	600	300	752	1,8	3,230	460460
SVPR 75x600x400	75	600	400	677	1,8	3,261	460470
SVPR 75x600x500	75	600	500	622	1,8	3,321	460480

Coating types:

- 1) Electro galvanized (2,5-10 mm)
- 2) Zink coating acc.to Sendzimir method (19-20 mm)
- 3) Hot dipped galvanized (50-100 mm)

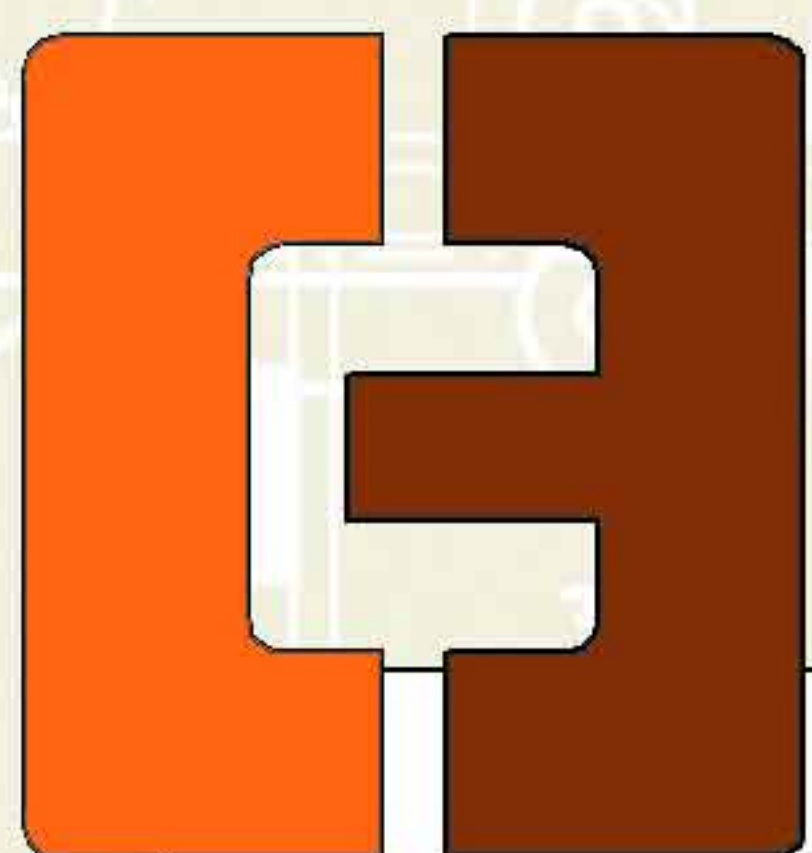

SVPR 100 T-adapter right hand

SVPR 100x300x200	100	300	200	622	1,2	1,992	460490
SVPR 100x400x200	100	400	200	677	1,2	2,155	460500
SVPR 100x400x300	100	400	300	622	1,2	2,179	460510
SVPR 100x500x200	100	500	200	752	1,2	2,343	460520
SVPR 100x500x300	100	500	300	677	1,2	2,342	460530
SVPR 100x500x400	100	500	400	622	1,2	2,367	460540
SVPR 100x600x200	100	600	200	677	1,2	2,342	460550
SVPR 100x600x300	100	600	300	752	1,2	2,527	460560
SVPR 100x600x400	100	600	400	677	1,2	2,529	460570
SVPR 100x600x500	100	600	500	622	1,2	2,554	460580
SVPR 100x300x200	100	300	200	622	1,5	2,490	460590
SVPR 100x400x200	100	400	200	677	1,5	2,693	460600
SVPR 100x400x300	100	400	300	622	1,5	2,723	460610
SVPR 100x500x200	100	500	200	752	1,5	2,928	460620
SVPR 100x500x300	100	500	300	677	1,5	2,927	460630
SVPR 100x500x400	100	500	400	622	1,5	2,958	460640
SVPR 100x600x200	100	600	200	677	1,5	2,927	460650
SVPR 100x600x300	100	600	300	752	1,5	3,158	460660
SVPR 100x600x400	100	600	400	677	1,5	3,161	460670
SVPR 100x600x500	100	600	500	622	1,5	3,192	460680
SVPR 100x300x200	100	300	200	622	1,8	2,988	460690
SVPR 100x400x200	100	400	200	677	1,8	3,232	460700
SVPR 100x400x300	100	400	300	622	1,8	3,268	460710
SVPR 100x500x200	100	500	200	752	1,8	3,514	460720
SVPR 100x500x300	100	500	300	677	1,8	3,513	460730
SVPR 100x500x400	100	500	400	622	1,8	3,550	460740
SVPR 100x600x200	100	600	200	677	1,8	3,513	460750
SVPR 100x600x300	100	600	300	752	1,8	3,790	460760
SVPR 100x600x400	100	600	400	677	1,8	3,793	460770
SVPR 100x600x500	100	600	500	622	1,8	3,831	460780

Coating types:

- 1) Electro galvanized (2,5-10 mm)
- 2) Zink coating acc.to Sendzimir method (19-20 mm)
- 3) Hot dipped galvanized (50-100 mm)

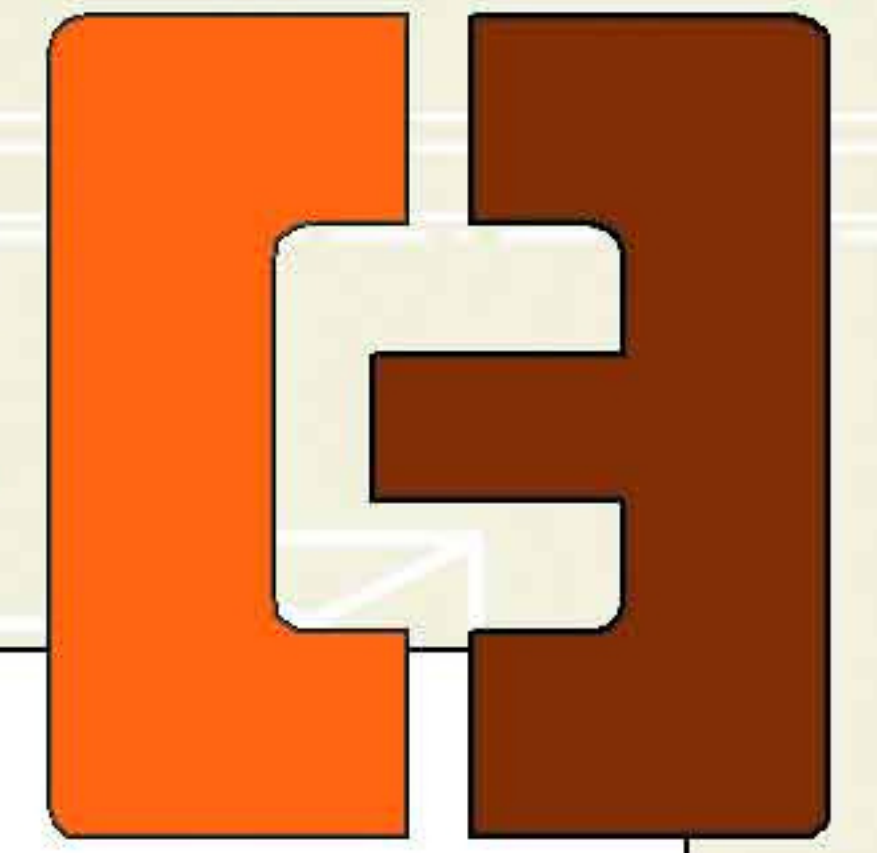

VSL 40 ladder type vertical cable trays (straight section)

Type	Height H, mm	Width B, mm	Length L, mm	Thickness/ cross-channel S, mm	Thickness/ lengthwise channel S, mm	Part number
VSL 40x200x3	40	200	3000	2,5	1,5	460790
VSL 40x200x6	40	200	6000	2,5	1,5	460800
VSL 40x300x3	40	300	3000	2,5	1,5	460810
VSL 40x300x6	40	300	6000	2,5	1,5	460820
VSL 40x400x3	40	400	3000	2,5	1,5	460830
VSL 40x400x6	40	400	6000	2,5	1,5	460840
VSL 40x500x3	40	500	3000	2,5	1,5	460850
VSL 40x500x6	40	500	6000	2,5	1,5	460860
VSL 40x600x3	40	600	3000	2,5	1,5	460870
VSL 40x600x6	40	600	6000	2,5	1,5	460880
VSL 40x700x3	40	700	3000	2,5	1,5	460890
VSL 40x700x6	40	700	6000	2,5	1,5	460900
VSL 40x800x3	40	800	3000	2,5	1,5	460910
VSL 40x800x6	40	800	6000	2,5	1,5	460920
VSL 40x900x3	40	900	3000	2,5	1,5	460930
VSL 40x900x6	40	900	6000	2,5	1,5	460940
VSL 40x1000x3	40	1000	3000	2,5	1,5	460950
VSL 40x1000x6	40	1000	6000	2,5	1,5	460960
VSL 40x1100x3	40	1100	3000	2,5	1,5	460970
VSL 40x1100x6	40	1100	6000	2,5	1,5	460980
VSL 40x1200x3	40	1200	3000	2,5	2,5	460990
VSL 40x1200x6	40	1200	6000	2,5	2,5	470010

Coating types:

- 1) Electro galvanized (2,5-10 mm)
- 2) Zink coating acc.to Sendzimir method (19-20 mm)
- 3) Hot dipped galvanized (50-100 mm)

VSL 60 ladder type vertical cable trays (straight section)

Type	Height H, mm	Width B, mm	Length L, mm	Thickness/ cross-channel S, mm	Thickness/ lengthwise channel S, mm	Part number
VSL 60x200x3	60	200	3000	2,5	2,5	470020
VSL 60x200x6	60	200	6000	2,5	2,5	470030
VSL 60x300x3	60	300	3000	2,5	2,5	470040
VSL 60x300x6	60	300	6000	2,5	2,5	470050
VSL 60x400x3	60	400	3000	2,5	2,5	470060
VSL 60x400x6	60	400	6000	2,5	2,5	470070
VSL 60x500x3	60	500	3000	2,5	2,5	470080
VSL 60x500x6	60	500	6000	2,5	2,5	470090
VSL 60x600x3	60	600	3000	2,5	2,5	470100
VSL 60x600x6	60	600	6000	2,5	2,5	470110
VSL 60x700x3	60	700	3000	2,5	2,5	470120
VSL 60x700x6	60	700	6000	2,5	2,5	470130
VSL 60x800x3	60	800	3000	2,5	2,5	470140
VSL 60x800x6	60	800	6000	2,5	2,5	470150
VSL 60x900x3	60	900	3000	2,5	2,5	470160
VSL 60x900x6	60	900	6000	2,5	2,5	470170
VSL 60x1000x3	60	1000	3000	2,5	2,5	470180
VSL 60x1000x6	60	1000	6000	2,5	2,5	470190
VSL 60x1100x3	60	1100	3000	2,5	2,5	470200
VSL 60x1100x6	60	1100	6000	2,5	2,5	470210
VSL 60x1200x3	60	1200	3000	2,5	2,5	470220
VSL 60x1200x6	60	1200	6000	2,5	2,5	470230

Coating types:

- 1) Electro galvanized (2,5-10 mm)
- 2) Zink coating acc.to Sendzimir method (19-20 mm)
- 3) Hot dipped galvanized (50-100 mm)

VSL 62 ladder type vertical cable trays (straight section)

Type	Height H, mm	Width B, mm	Length L, mm	Thickness/ cross-channel S, mm	Thickness/ lengthwise channel S, mm	Part number
VSL 62x200x3	62	200	3000	2,5	2,5	470240
VSL 62x200x6	62	200	6000	2,5	2,5	470250
VSL 62x300x3	62	300	3000	2,5	2,5	470260
VSL 62x300x6	62	300	6000	2,5	2,5	470270
VSL 62x400x3	62	400	3000	2,5	2,5	470280
VSL 62x400x6	62	400	6000	2,5	2,5	470290
VSL 62x500x3	62	500	3000	2,5	2,5	470300
VSL 62x500x6	62	500	6000	2,5	2,5	470310
VSL 62x600x3	62	600	3000	2,5	2,5	470320
VSL 62x600x6	62	600	6000	2,5	2,5	470330
VSL 62x700x3	62	700	3000	2,5	2,5	470340
VSL 62x700x6	62	700	6000	2,5	2,5	470350
VSL 62x800x3	62	800	3000	2,5	2,5	470360
VSL 62x800x6	62	800	6000	2,5	2,5	470370
VSL 62x900x3	62	900	3000	2,5	2,5	470380
VSL 62x900x6	62	900	6000	2,5	2,5	470390
VSL 62x1000x3	62	1000	3000	2,5	2,5	470400
VSL 62x1000x6	62	1000	6000	2,5	2,5	470410
VSL 62x1100x3	62	1100	3000	2,5	2,5	470420
VSL 62x1100x6	62	1100	6000	2,5	2,5	470430
VSL 62x1200x3	62	1200	3000	2,5	2,5	470440
VSL 62x1200x6	62	1200	6000	2,5	2,5	470450

Coating types:

- 1) Electro galvanized (2,5-10 mm)
- 2) Zink coating acc.to Sendzimir method (19-20 mm)
- 3) Hot dipped galvanized (50-100 mm)

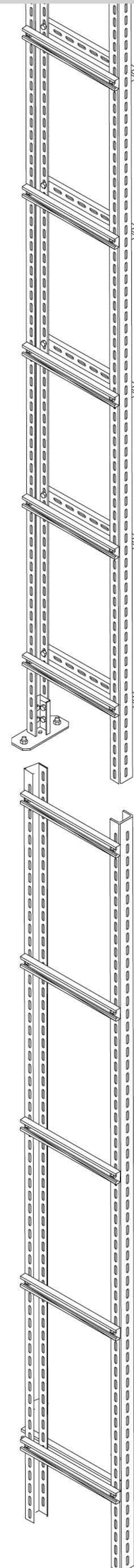



**STANDART
ELECTRIC**

SCP cable tray connector

Type	Height H, mm	Length L, mm	Thickness S, mm	Weight, kg/quantity	Part number
SCP 50	44	200	2,0	0,135	470460
SCP 75	71	200	2,0	0,209	470470
SCP 100	70	200	2,0	0,220	470480

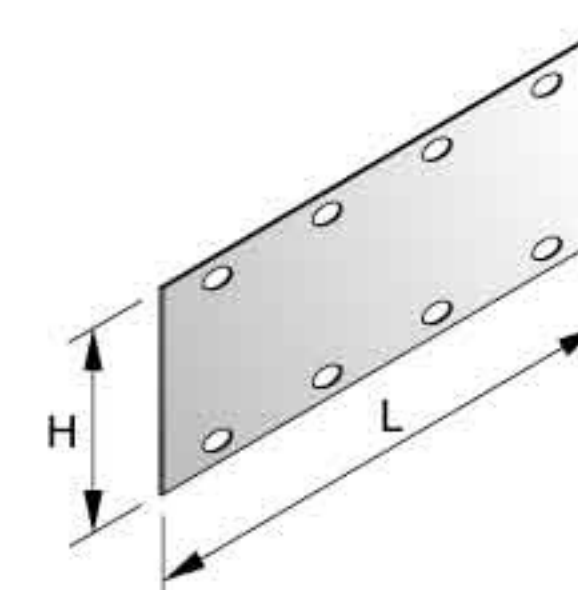

Coating types:

- 1) Electro galvanized (2,5-10 mm)
- 2) Zink coating acc.to Sendzimir method (19-20 mm)
- 3) Hot dipped galvanized (50-100 mm)

SCPH hinged tray connector

Type	Height H, mm	Length L, mm	Thickness S, mm	Weight, kg/quantity	Part number
SCPH 50	45	132	2,0	0,065	470490
SCPH 75	70	170	2,0	0,150	470500
SCPH 100	70	170	2,0	0,150	470510

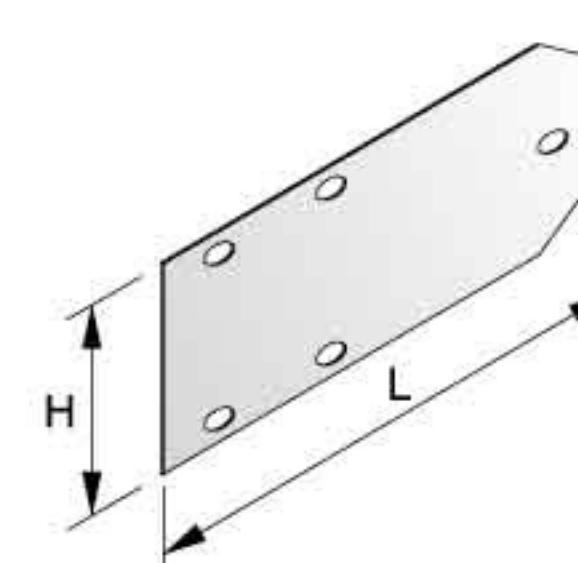

Coating types:

- 1) Electro galvanized (2,5-10 mm)
- 2) Zink coating acc.to Sendzimir method (19-20 mm)
- 3) Hot dipped galvanized (50-100 mm)

SLC tray bracket connector

Type	Height H, mm	Width B, mm	Length L, mm	Thickness S, mm	Weight, kg/quantity	Part number
SLC 90x50x1,5	90	50	325	1,5	0,505	470520

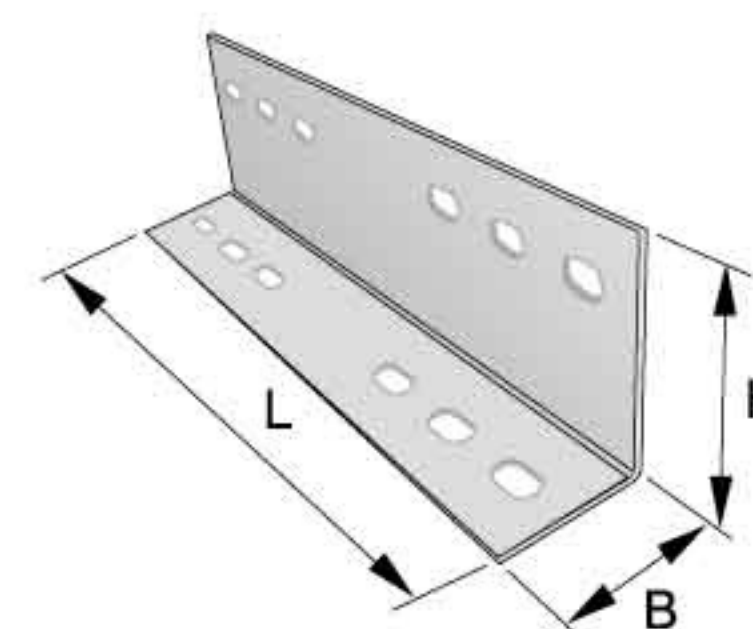

Coating types:

- 1) Electro galvanized (2,5-10 mm)
- 2) Zink coating acc.to Sendzimir method (19-20 mm)
- 3) Hot dipped galvanized (50-100 mm)

CP press clip

Type	Height H, mm	Length L, mm	Thickness S, mm	Weight, kg/quantity	Part number
CP	40	70	2,0	0,044	470530

Материал: ОЦ, ГО, НС

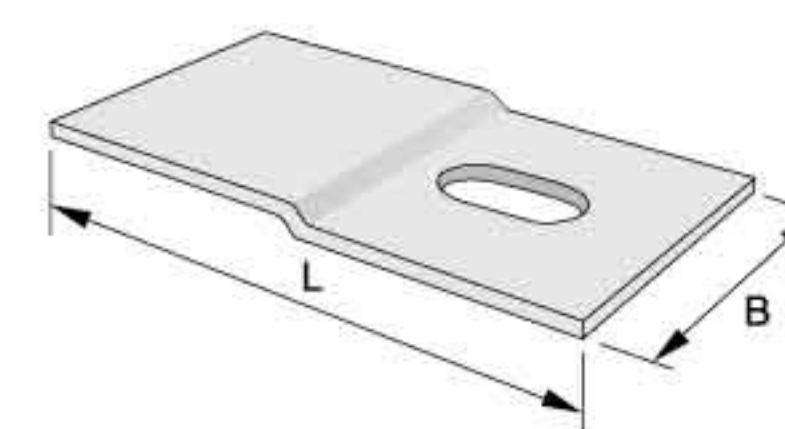

Coating types:

- 1) Electro galvanized (2,5-10 mm)
- 2) Zink coating acc.to Sendzimir method (19-20 mm)
- 3) Hot dipped galvanized (50-100 mm)

CPB press clip

Type	Height H, mm	Width B, mm	Length L, mm	Thickness S, mm	Weight, kg/quantity	Part number
CPB 50	54	40	42	2,0	0,096	470540
CPB 75	78	40	42	2,0	0,119	470550
CPB 100	102	40	42	2,0	0,141	470560

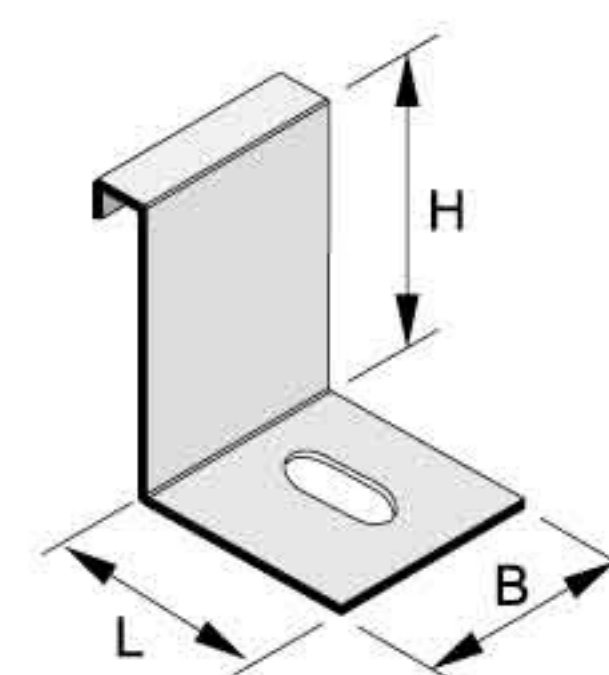

Coating types:

- 1) Electro galvanized (2,5-10 mm)
- 2) Zink coating acc.to Sendzimir method (19-20 mm)
- 3) Hot dipped galvanized (50-100 mm)

SFKC fixing for tray cover

Type	Height H, mm	Width B, mm	Length L, mm	Thickness S, mm	Weight, kg/quantity	Part number
SFKC 50	62	20	25	4,0	0,05	470570
SFKC 75	87	20	25	4,0	0,07	470580
SFKC 100	113	20	25	4,0	0,09	470590

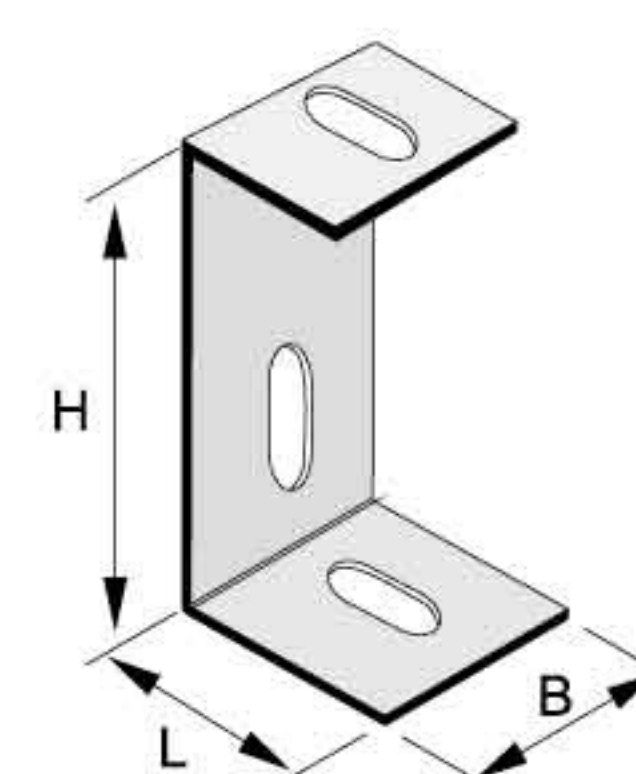

Coating types:

- 1) Electro galvanized (2,5-10 mm)
- 2) Zink coating acc.to Sendzimir method (19-20 mm)
- 3) Hot dipped galvanized (50-100 mm)



STANDART
ELECTRIC

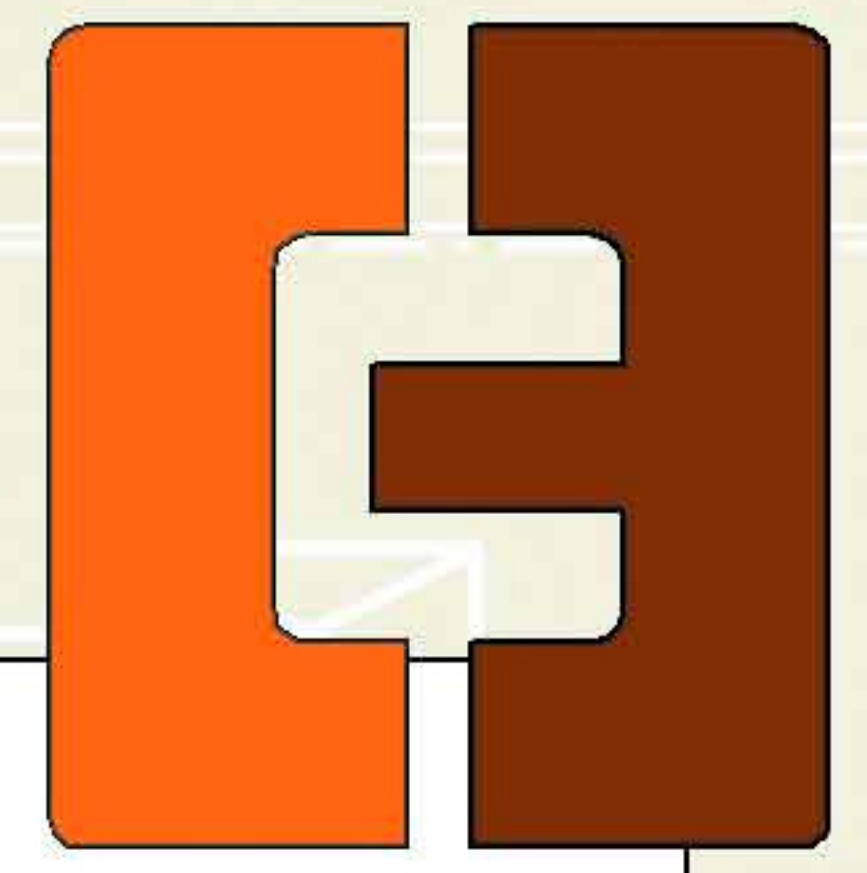



STANDART
ELECTRIC

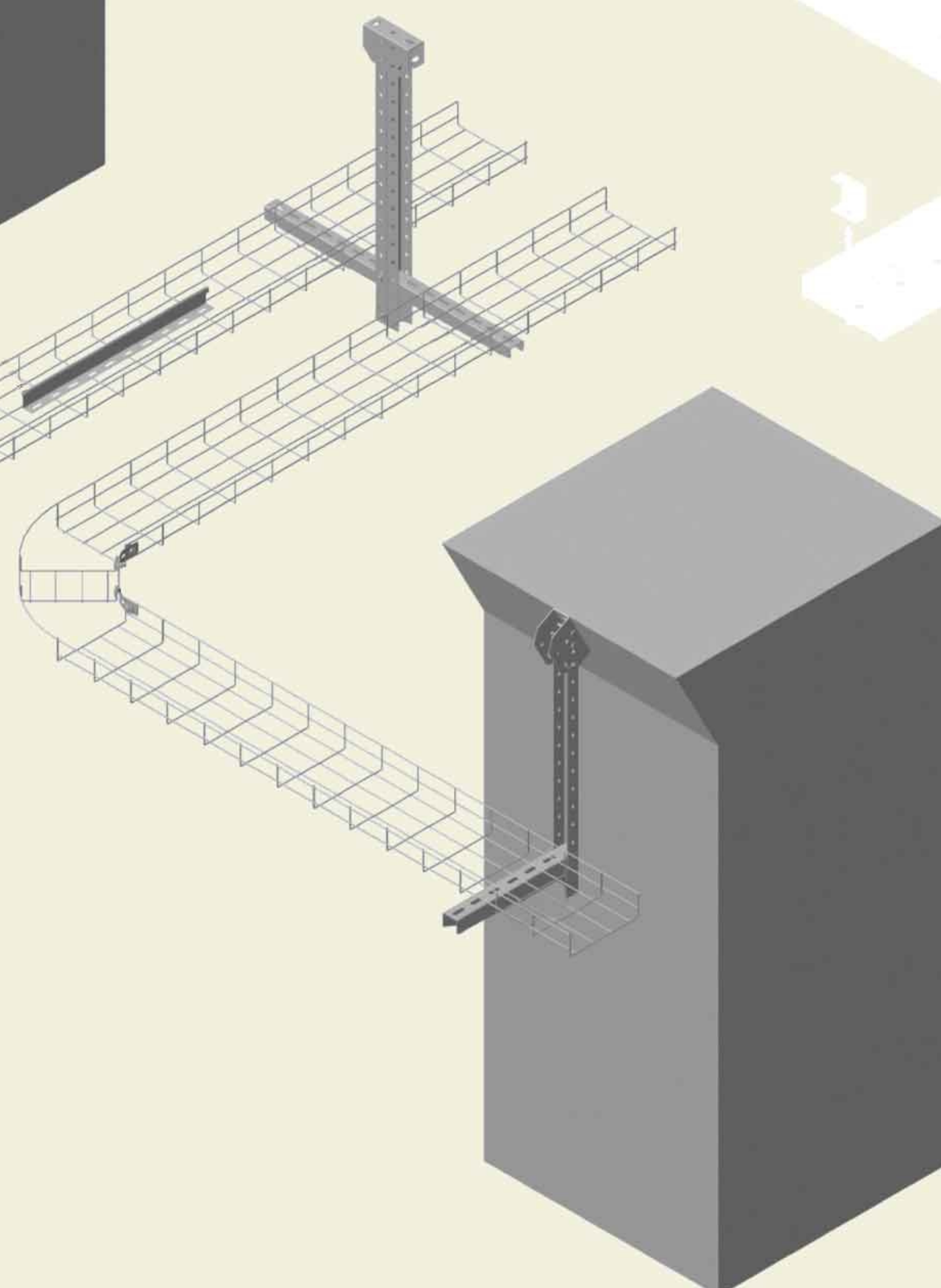
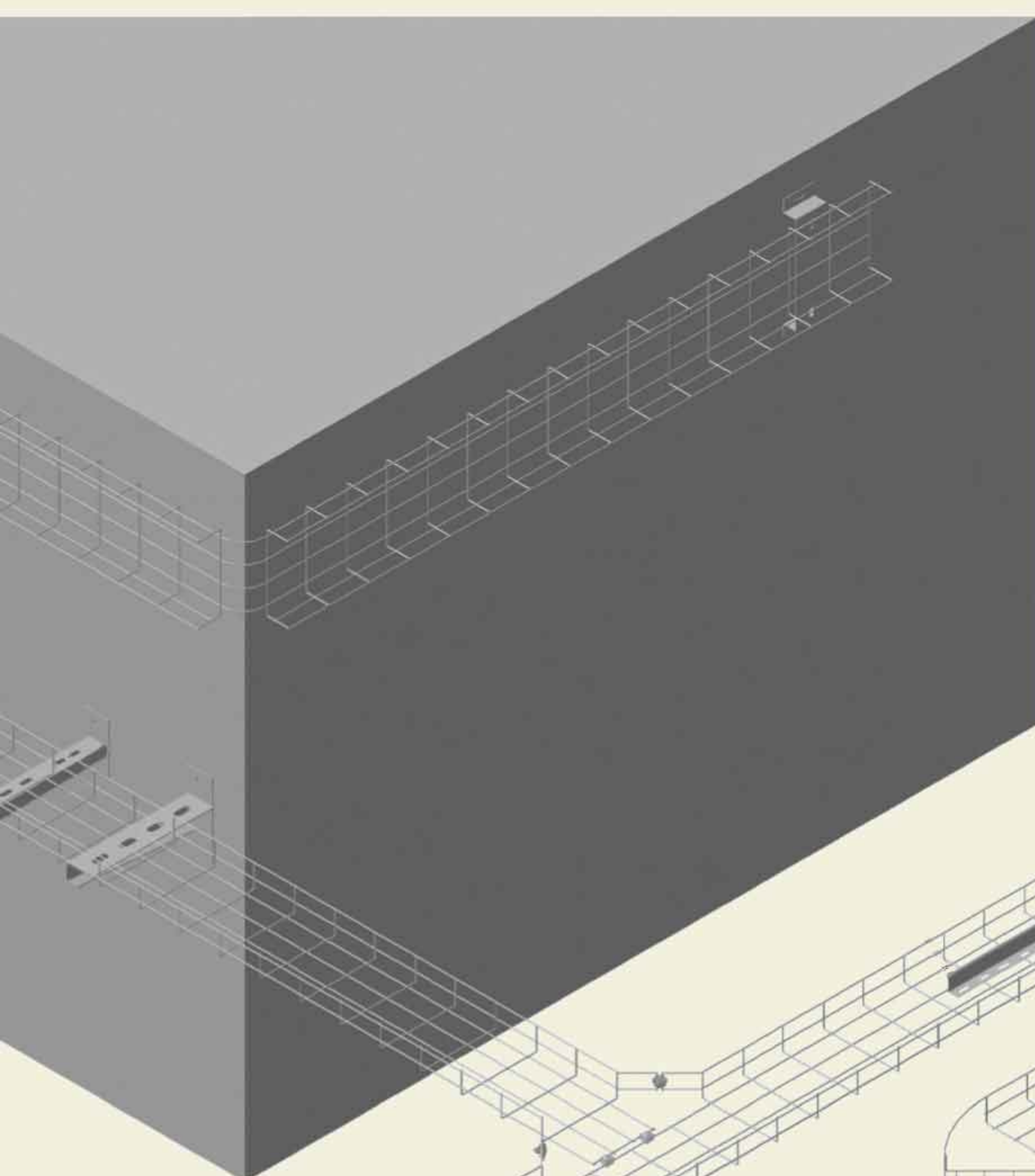

Standart-electric Ltd.

117042, Moscow
Admirala Lazareva St., h.52, build. 3
Tel.: +7(495)972-21-85
e-mail: info@st-electric.ru, www.st-electric.ru

